

# MARTIN® BOCO™ Self-Adjusting Skirting



**MARTIN® BOCO™ Self-Adjusting Skirting** provides an effective skirtboard seal that eliminates spillage and prevents the problems caused by fugitive material. It self-adjusts to eliminate skirtboard maintenance.

As it requires only 1.25 inches (32 mm) of free belt space outside the chute, MARTIN® BOCO™ Self-Adjusting Skirting is the ideal sealing system for conveyors with chutes close to the belt edge. The rubber and clamp assembly can be installed in spaces as low as six inches (150 mm) above the belt.

## BENEFITS

- “Self-Adjusts” to Maintain Effective Barrier.
- Installs Easily in Tight Clearances.
- Simple “No-Tool” Rubber Replacement.
- Prevents Regulatory Problems from Spillage.
- Minimizes Cleanup Labor and Expense.
- Preserves Conveyor Components from Fugitive Material.
- Keeps Cargo on Belt to Improve Conveyor Efficiency.

## SPECIFICATIONS

Seal Strip	
Material	EPDM Rubber
Thickness	0.75 in (19 mm)
Wear Life	2 in. (51 mm)
Durometer	70 Shore A
Temperature Range	-20° to 250°F (-29° to 121°C)
Maximum Belt Speed	700 fpm (3.5 m/s)
Clamp Assembly (Wear Strip and Pressure Plate)	
Material	Mild Steel
Length	48 in. (1219 mm)
Installed Height	6 in. (152 mm)

Refer to Sealing System Selection Guide (Form No. L3636 for material specifications and application criteria.

## NOTES

- **Maintains Seal Without Maintenance**  
System rides on belt, self-adjusting to maintain effective seal automatically as belt path fluctuates and sealing strip wears.
- **Lowest Belt Edge Requirement**  
Fits on any belt; provides effective seal on conveyors where chute width leaves as little as 1.25 inches (32 mm) of free belt area for sealing.
- **Compact System Fits Tight Places**  
Low-profile skirting assembly needs only six inches (152 mm) of clearance, allowing installation in small spaces.
- **Quick and Easy to Install**  
Short 48-inch (1219-mm) clamp sections with built-in plug-weld guides simplify installation.
- **Long-Lasting Performance**  
Durable sealing strip provides 2-inch (51-mm) wear life. Zinc-plated moving parts will not seize or rust together.
- **“No-Tool” Rubber Replacement**  
Held in place with linchpins, replacement of the worn sealing strip is a quick, easy, no-tool operation.
- **No Leaky Joints**  
No spillage at joints in sealing strip; rubber strip supplied in continuous lengths up to 100 feet (30.48 m).
- **Guaranteed Installation Available from Martin Services**

# TECHNICAL DATA SHEET

DIMENSIONS – in. (mm)

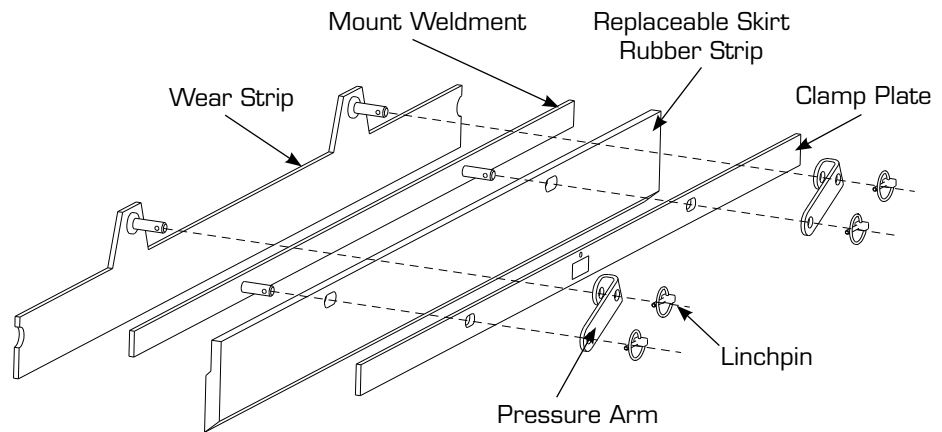
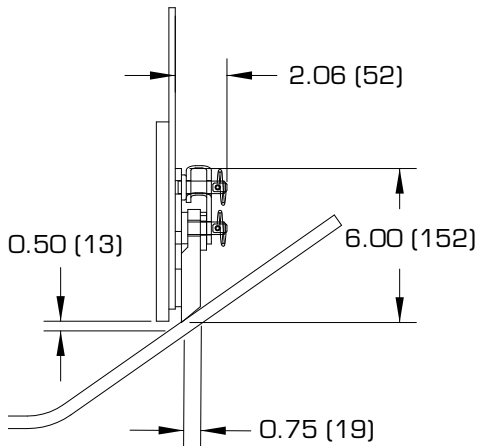

## ORDER INFORMATION

MARTIN® BOCO™ Self-Adjusting Skirting	Length	Part Number
MARTIN® BOCO™ Self-Adjusting Skirting Assembly	48 in. (1219 mm)	37911
MARTIN® BOCO™ Self-Adjusting Skirting Rubber Strip	Maximum of 100 ft (30.48 m)	37911-R Specify length required in feet
Owner Operator Manual Installation Kit	NA	37911-C

Order enough Clamp Assemblies to match installation requirements for both sides of conveyor.

Order Rubber Strip in one length and field cut it into two strips to cover both sides of your conveyor.

Order one Installation Kit per entire installation (includes installation spacing guides and instructions).

## NOTES

MARTIN® BOCO™ Self-Adjusting Skirting is not suitable for installation on conveyors that reverse or roll back.

Failure to keep the belt tracking properly may result in spillage, premature failure of the skirt rubber, and damage to the belt or structure.

Installation of MARTIN® DURT TAMER™ Wear Liner is recommended to protect sealing system from pressure of material load.

MARTIN® BOCO™ Self-Adjusting Skirting should begin at least 6 inches (152 mm) before the inlet side of the chute wall (closest to the tail pulley) and extend beyond the end of the chute. As MARTIN® BOCO™ Self-Adjusting Skirting wears from new to completely worn, the system will move backward on the conveyor approximately 3 inches (76 mm).



**Martin Engineering USA**  
 One Martin Place  
 Neponset, IL 61345-9766 USA  
 800 544 2947 or 309 852 2384  
 Fax 800 814 1553  
[www.martin-eng.com](http://www.martin-eng.com)

Subject to change without prior notice.  
 Patents and patents pendings, ® registered trademark of Martin Engineering Company in the U.S. and other select locations.  
 Additional information can be obtained at [www.martin-eng.com/trademarks](http://www.martin-eng.com/trademarks).

QUALITY MANAGEMENT SYSTEM  
 CERTIFIED BY DNV  
**ISO 9001:2008**

**Problem Solved™**

Form No. L3617-08/11  
 © Martin Engineering Company 2011