

BIG BLASTER® HURRICANE Air Cannon

The **BIG BLASTER® HURRICANE Air Cannon** features a new valve concept that provides more force, uses less air, and simplifies installation and maintenance.

The BIG BLASTER® HURRICANE Air Cannon fires in response to a positive surge of air sent by a solenoid valve. This positive-acting valve delivers twice the force output while using only half the air volume than that of a standard BIG BLASTER® XHV 20-30 Air Cannon. *70 liter HURRICANE Air Cannon

BENEFITS

- More force output
- One-step maintenance
- Suitable for high-temperature applications



BIG BLASTER® CATEGORY 5 HURRICANE Multi-Valve Air Cannon System**

PERFORMANCE DATA

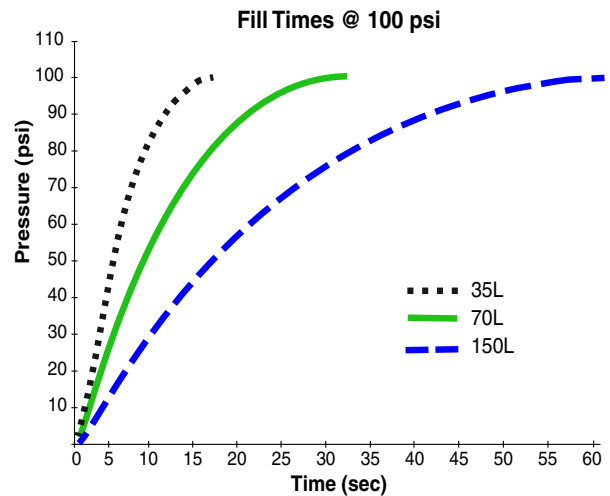
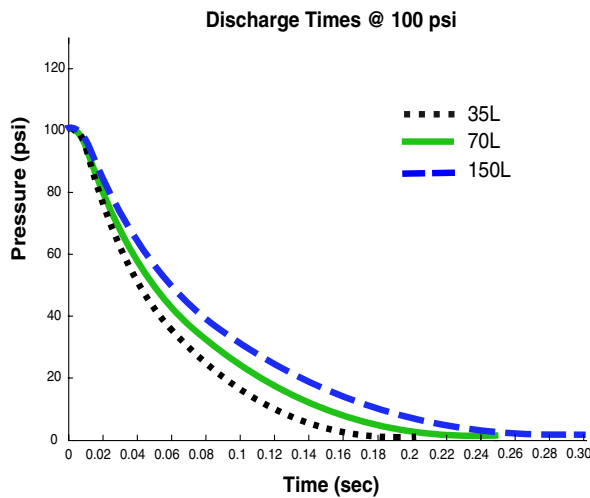

TECHNICAL DATA SHEET

DIMENSIONS

Model	P/N	Dim. A in. (mm)	Dim. B in. (mm)	Dim. C in. (mm)	Shipping Weight lb (kg)
HURRICANE	38005-35	16.0 (406)	24.92 (633)	20.00 (508)	78 (35)
HURRICANE	38005-70	20.0 (508)	27.92 (709)	23.00 (584)	94 (43)
HURRICANE	38005-150	24.0 (610)	35.67 (906)	30.75 (781)	130 (59)

NPT—National Pipe Thread

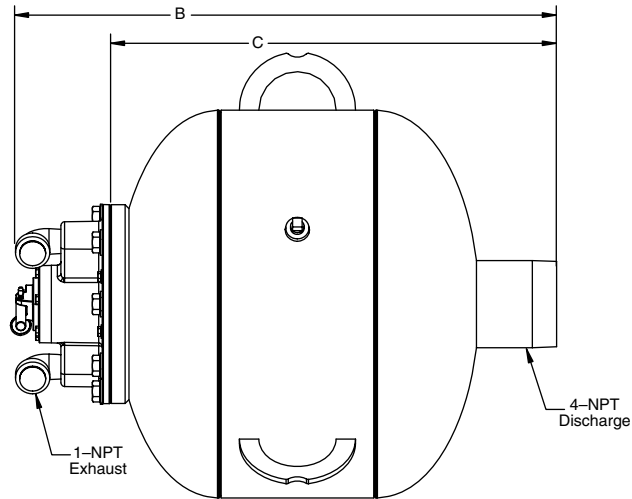
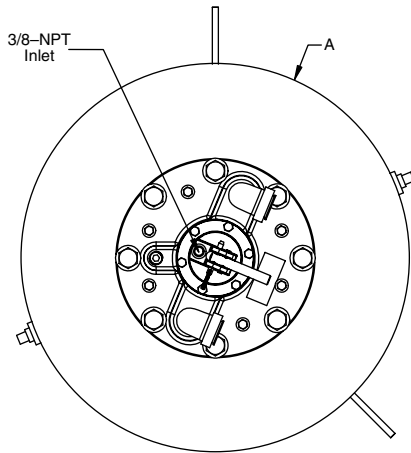

AIR VOLUME IN FT³ (LITERS) FREE AIR

Air Pressure PSI	38005-35 ft ³ (L)	38005-70 ft ³ (L)	38005-150 ft ³ (L)
0	1.2 (35)	2.4 (70)	5.3 (150)
40	4.6 (130)	9.2 (260)	19.7 (558)
50	5.4 (153)	10.8 (308)	23.3 (660)
60	6.2 (176)	12.5 (355)	26.9 (762)
70	7.1 (201)	14.2 (403)	30.5 (864)
80	7.9 (224)	15.9 (450)	34.1 (966)
90	8.8 (249)	17.6 (498)	37.8 (1020)
100	9.6 (272)	19.2 (546)	41.4 (1172)
110	10.4 (294)	20.9 (593)	45.0 (1274)
120	11.3 (320)	22.6 (641)	48.6 (1376)

NOTES

Tanks for BIG BLASTER® Air Cannons supplied by Martin Engineering are manufactured to ASME Code Rules, Section VIII, Division 1. Tanks are National Board registered and pressure vessel quality (PVQ).

**For further information, contact Martin Engineering at 1-800-544-2947 or visit our website at www.martin-eng.com.



Martin Engineering USA

One Martin Place
Neponset, IL 61345-9766 USA
800 544 2947 or 309 852 2384
Fax 800 814 1553
www.martin-eng.com

Patents and patents pending. © Registered trademark of Martin Engineering Company in the US and other select locations.

QUALITY MANAGEMENT SYSTEM
CERTIFIED BY DNV

ISO 9001:2008

Problem Solved™

Form No. L3800-08/11
© Martin Engineering Company 2011