



# **BRUTE<sup>®</sup>** **Vibrators**

[Go to BRUTE<sup>®</sup> Vibrators web page](#)



**Operator's Manual**  
**M3193**

# Important

MARTIN ENGINEERING HEREBY DISCLAIMS ANY LIABILITY FOR: DAMAGE DUE TO CONTAMINATION OF THE MATERIAL; USER'S FAILURE TO INSPECT, MAINTAIN AND TAKE REASONABLE CARE OF THE EQUIPMENT; INJURIES OR DAMAGE RESULTING FROM USE OR APPLICATION OF THIS PRODUCT CONTRARY TO INSTRUCTIONS AND SPECIFICATIONS CONTAINED HEREIN. MARTIN ENGINEERING'S LIABILITY SHALL BE LIMITED TO REPAIR OR REPLACEMENT OF EQUIPMENT SHOWN TO BE DEFECTIVE.

Observe all safety rules given herein along with owner and Government standards and regulations. Know and understand lockout/tagout procedures as defined by American National Standards Institute (ANSI) z244.1-1982, *American National Standard for Personnel Protection - Lockout/Tagout of Energy Sources - Minimum Safety Requirements* and Occupational Safety and Health Administration (OSHA) Federal Register, Part IV, 29 CFR Part 1910, *Control of Hazardous Energy Source (Lockout/Tagout); Final Rule*.

The following symbols may be used in this manual:



**Danger:** Immediate hazards that will result in severe personal injury or death.



**Warning:** Hazards or unsafe practices that could result in personal injury.



**Caution:** Hazards or unsafe practices that could result in product or property damages.



**Important:** Instructions that must be followed to ensure proper installation/operation of equipment.



**Note:** General statements to assist the reader.

# Table of Contents

---

<b>Section</b>	<b>Page</b>
List of Figures .....	ii
List of Tables .....	ii
Introduction .....	1
General .....	1
References .....	1
Safety .....	1
Materials required .....	1
Model identification .....	1
Cases .....	2
Motors .....	2
Series .....	2
Unit weights .....	3
Before Installing Vibrator .....	4
Installing Vibrator .....	5
Mounting vibrator onto structure .....	5
After Installing Vibrator .....	9
Starting hydraulic vibrators .....	9
Starting pneumatic vibrators .....	10
Adjusting eccentric weights .....	11
Troubleshooting .....	14
Hydraulic vibrators .....	14
Pneumatic vibrators .....	14
Monthly Maintenance .....	15
Hydraulic vibrators .....	15
Pneumatic vibrators .....	15
Clamp foot parts replacement (CCV units) .....	16
Lubrication .....	16
Oil bath units .....	16
Greased units .....	17
Replacing air motor vane .....	17
Part Numbers .....	19
Appendix. BRUTE® Vibrator technical data .....	A-1

# List of Figures

Figure	Title	Page
1	Locating Vibrator on Hoppers .....	5
2	Locating Vibrator on Truck Bed.....	5
3	Skip Weld .....	6
4	Typical BRUTE® Vibrator Mounts.....	7
5	Removing Motor/Flange Assembly .....	12
6	Eccentric Weight Settings.....	12
7	5HB Hydraulic Motor Assembly, P/N 12959.....	21
8	2HB Hydraulic Motor Assembly, P/N 18484.....	22
9	8HA Hydraulic Motor Assembly, P/N 12965.....	24
10	2A Air Motor Assembly, P/N 27873 .....	26
11	Air Motor Assemblies, P/Ns 27874 (6A) or 11257 (6A) with springs and push pins included .....	28
12	CV2.0 Case Assembly (Greased) .....	30
13	CV2.8 Case Assembly (Greased), P/Ns 17903 or 29752 .....	31
14	CC2.8 Case Assembly (Greased), P/Ns 18480 or 29756 .....	32
15	DV4 Case Assemblies, P/Ns 29751 (Greased) or 29754 (Oil Bath) .....	33
16	CCV4 Case Assemblies, P/N 29755 (Greased) or 22024 (Oil Bath) .....	34
17	DV6 Case Assemblies (Greased or Oil Bath), P/N 22081 .....	35
18	CCV6 Case Assemblies, P/Ns 24377 (Greased) or 22080 (Oil Bath) .....	36
19	Air Motor Caution Label (P/N 22765) .....	37

# List of Tables

Table	Title	Page
I	Shipping Weights of Hydraulic BRUTE® Vibrators.....	3
II	Shipping Weights of Pneumatic BRUTE® Vibrators .....	3
III	Bolt Sizes and Torque .....	8
IV	DV6 and CCV6 Part Numbers .....	37

# Introduction

---

## **General**

BRUTE® Vibrators are equipped with motor-driven rotary eccentric weights that can be powered by a hydraulic or pneumatic motor, and deliver rotary vibration through a complete range of frequencies. The motor is attached to the separate head or case assembly containing the eccentric weights, bearings, and shaft. The motor shaft is inserted in the eccentric shaft and locked into place, which causes the eccentric weights to rotate with the motor shaft.

BRUTE® Vibrators are available in many different sizes and are available with portable or permanent mounts. Technical data for each BRUTE® Vibrator is provided in the Appendix.

## **References**

The following documents are referenced in this manual:

- *The National Electrical Code (NEC)*. National Fire Protection Association, 1 Batterymarch Park, P.O. Box 9101, Quincy MA 02269-9101.
- American National Standards Institute (ANSI) z244.1-1982, *American National Standard for Personnel Protection - Lockout/Tagout of Energy Sources - Minimum Safety Requirements*, American National Standards Institute, Inc., 1430 Broadway, New York, NY 10018.
- Federal Register, Volume 54, Number 169, Part IV, 29 CFR Part 1910, *Control of Hazardous Energy Source (Lockout/Tagout); Final Rule*, Department of Labor, Occupational Safety Health Administration (OSHA), 32nd Floor, Room 3244, 230 South Dearborn Street, Chicago, IL 60604.

## **Safety**

All safety rules in the above documents and all owner/employer safety rules must be strictly followed when working with this unit.

## **Materials required**

Only standard hand tools are required to install and maintain this equipment.

## **Model identification**

Each model of BRUTE® Vibrator is classified with an alphanumeric designation. Each letter and number represents a specific aspect of the vibrator.

Prefix letters:

- C = Two-bolt permanent mount
- CC = Quick-change or portable mount
- D = Four-bolt or six-bolt permanent mount
- V = Force output perpendicular to the mount

Model numbers:

- First digit = Radius of eccentric weight
- Second digit = Unbalance (in.-lb)
- Third digit = Motor size designator

## Suffix Letters:

- A = Pneumatic motor
- G = Greased case
- HA = Hydraulic motor
- HB = Hydraulic motor
- S = Sealed case

## Example: CCV 6-50-8HA

- CC = Quick-change clamp mount
- V = Force output perpendicular to mount
- 6 = Eccentric weight radius (case)
- 50 = Weight/unbalance (in.-lbs)
- 8 = Motor size designator
- HA = Hydraulic Motor

## *Cases*

Four different BRUTE® Vibrator Series cases are available: 2.0, 2.8, 4, and 6. The 2.0, 2.8, and 4 case Vibrators feature adjustable eccentric weights to meet optimum force and frequency requirements. The 6 case Vibrators feature fixed eccentric weights in 12-, 25-, or 50-in.-lb sizes.

## *Motors*

BRUTE® Hydraulic Vibrators are available in three motor sizes: 2HB, 5HB, and 8HA, and are sized according to the in.-lb unbalance of the eccentric weight size.

BRUTE® Pneumatic Vibrators are available in two air motor sizes: 2A and 6A.

## *Series*

Four different BRUTE® Vibrator Series are available:

- CCV: Available in two sizes (CCV4 and CCV6). These units feature clamp feet for use as portable units.
- DV: Available in two sizes (DV4 and DV6). These units are base-mounted for permanent installations.
- CV: Available in two sizes (CV2.0 and CV2.8). This unit has a base mount which can be used for permanent mounting or with clamp blocks. A bracket can also be used for portability for railcar unloading.
- CC: One size is available (CC2.8). This unit is mounted in a cradle lug bracket, and is ideal for concrete work where multiple lug brackets are used to mount the vibrator in various locations.

## *Unit weights*

Tables I and II list shipping weights of all BRUTE® Vibrators.

**Table I. Shipping Weights of Hydraulic BRUTE® Vibrators**

<b>Model No.</b>	<b>Weight lb (kg)</b>
CV2.0-2HB	23 (10.4)
CC2.8-5HB	45 (20.4)
CV2.8-5HB	52 (23.6)
CCV4-5HB	60 (27.2)
DV4-5HB	70 (31.8)
CCV6-12-8HA	110 (50.0)
CCV6-25-8HA	110 (50.0)
CCV6-50-8HA	110 (50.0)
DV6-12-8HA	115 (52.2)
DV6-25-8HA	115 (52.2)
DV6-50-8HA	115 (52.2)

**Table II. Shipping Weights of Pneumatic BRUTE® Vibrators**

<b>Model No.</b>	<b>Weight lb (kg)</b>
CC2.8-2A	45 (20.4)
CV2.8-2A	49 (22.2)
CCV4-2A	58 (26.3)
DV4-2A	70 (31.8)
CCV6-12-6A	110 (50.0)
CCV6-25-6A	110 (50.0)
CCV6-50-6A	110 (50.0)
DV6-12-6A	115 (52.2)
DV6-25-6A	115 (52.2)
DV6-50-6A	115 (52.2)

## Before Installing Vibrator

---

### **IMPORTANT**

**The delivery service is responsible for damage occurring in transit. Martin Engineering CANNOT enter claims for damages. Contact your transportation agent for more information.**

1. Inspect shipping container for damage. Report damage to delivery service immediately and fill out delivery service's claim form. Keep any damaged goods subject to examination.
2. Remove vibrator from shipping container.
3. If anything is missing or damaged, contact Martin Engineering or a representative.

### **⚠ WARNING**

**If equipment will be installed in an enclosed area, gas level or dust content must be tested before using a cutting torch or welding. Using a cutting torch or welding in an area with gas or dust may cause an explosion.**

4. If using a cutting torch or welding, test atmosphere for gas level or dust content.
5. Make sure mounting surface is strong and flat, within 1/16 in. (2 mm) across vibrator feet. (This will prevent internal stress to vibrator casting when tightening mount bolts.)
6. Make sure mounting surface and vibrator are clean and free of debris.

## IMPORTANT

Read entire section before beginning work. This manual provides instructions for installation onto steel bins and hoppers only. For other installations, call Martin Engineering or a representative.

## CAUTION

If installation instructions are not followed, structure and vibrator can be damaged. Abusing or handling vibrator carelessly will accelerate wear and shorten bearing life.

### Mounting vibrator onto structure

1. See Figure 1. Locate vibrator in lower 1/4 to 1/3 of structure slope length. If second vibrator is required, mount 180° from first vibrator and halfway up slope.

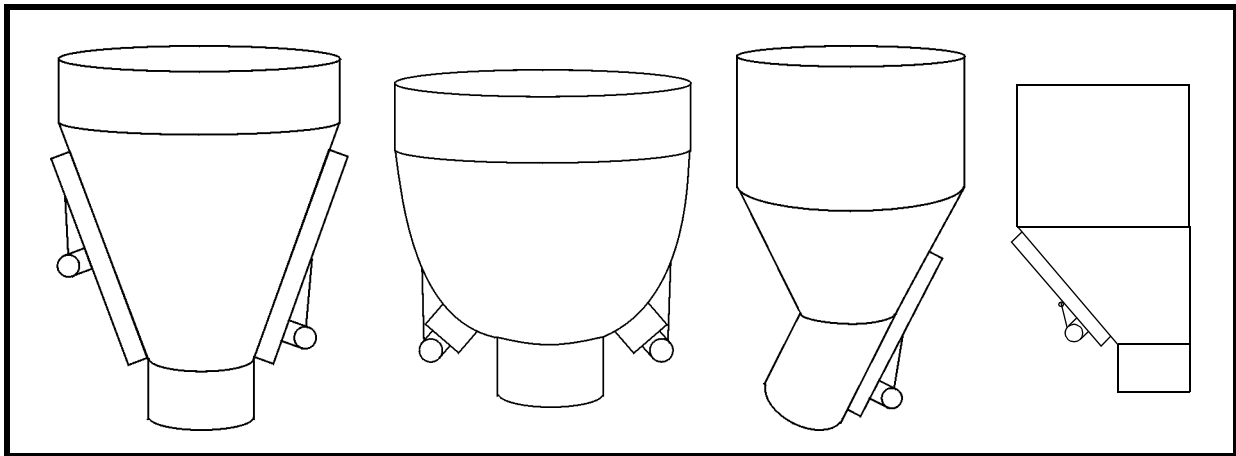

Figure 1. Locating Vibrator on Hoppers

2. For trucks, mount vibrator in center of front 1/3 of truck bed on 6 by 4-in. (152 by 102-mm) channel, or on rigid member of truck bed (see Figure 2). If two vibrators are required, mount 1/4 of width from each side in front 1/3 of truck bed.

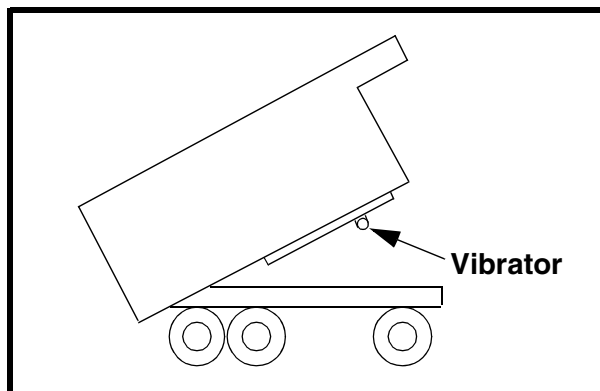

Figure 2. Locating Vibrator on Truck Bed

## ⚠ CAUTION

Never weld structure with vibrator mounted and wired. Welding may cause damage to motor components and bearings.

## IMPORTANT

The object of rotary vibration on bins, hoppers, and chutes is to transmit vibration through the wall into the product contained inside. If structure is not made rigid, vibrator may draw high amperage or move material less efficiently.

3. If using reinforcing beam to strengthen hopper wall, do the following:
  - a. Locate reinforcing beam so vibrator can be positioned as shown in Figure 1 or 2.
  - b. Extend beam at least 3/4 the length of the sloped wall. Cut off end(s) of beam if necessary to fit on structure.
  - c. See Figure 3. Skip weld channel or beam onto hopper wall: Weld 3 in. (76 mm), then skip 2 in. (51 mm). Do not weld last 1 in. (25 mm) or either end of beam or any corner.

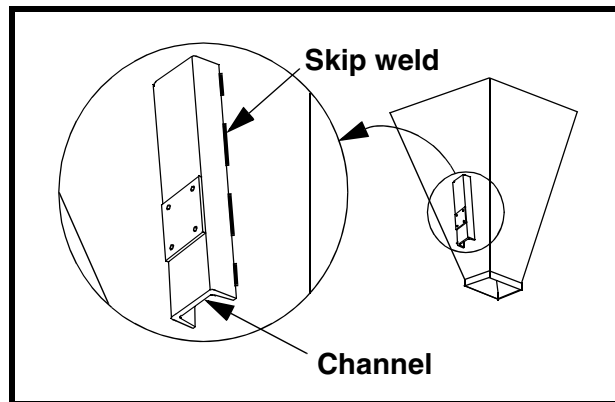

**Figure 3. Skip Weld**

4. If using customer-supplied mounting plate to mount vibrator onto structure, do the following:
  - a. Make sure plate is at least size of vibrator base.
  - b. Locate plate so that vibrator can be positioned as shown in Figure 1 or 2.
  - c. Weld mounting plate onto structure.
5. If using cradle lug bracket or LBF mount, weld onto structure. (See Figure 4.)

**⚠ CAUTION**

**Never weld structure with vibrator mounted and wired. Welding may cause damage to motor components and bearings.**

**Use only new bolts, lock nuts, and compression washers to install vibrator. Old fasteners can break and cause damage to vibrator or structure.**

**Do not use split lock washers to install vibrator onto mount. Damage to vibrator could result.**

6. Before installing vibrator onto mount, apply thread sealing compound to all bolts.
7. Install vibrator onto mounting plate with new Grade 5 lock nuts, compression washers, and bolts. See Table III for specific size and torque requirements. Use lock nuts and lock washers same size as bolts.
8. Install vibrator onto clamp mounts or LBM wedge as follows:
  - a. Align mounting holes in vibrator with mounting holes in mount.
  - b. Install vibrator onto mount with four new lock nuts, compression washers, and Grade 5 bolts. (See Table III for specific size and torque requirements.) Use lock nuts and lock washers same size as bolts.

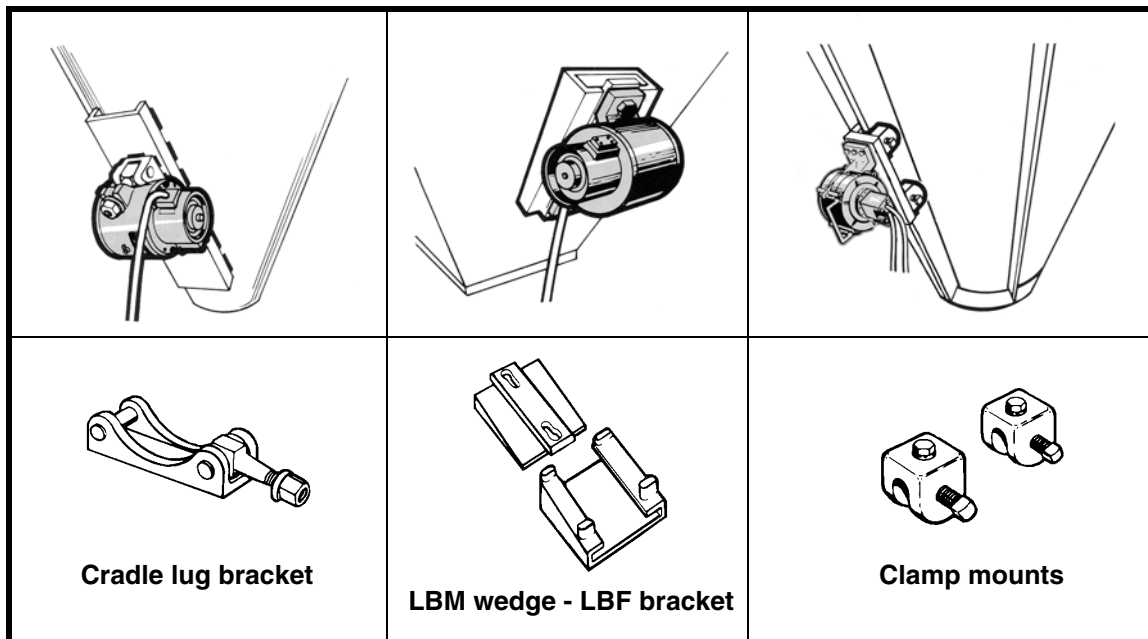

**Figure 4. Typical BRUTE® Vibrator Mounts**

9. After vibrator has operated for 10 to 20 minutes, check bolt torque. Tighten if necessary.

**Table III. Bolt Sizes and Torque**

Bolt size	Bolt torque	
	ft-lb	kgm
1/2-in. - 13 NC	78 ft-lb	11
9/16-in. - 12 NC	114 ft-lb	16
5/8-in. - 11 NC	154 ft-lb	21
3/4-in. - 10 NC	257 ft-lb	36
7/8-in. - 9 NC	382 ft-lb	53
1-in. - 8 NC	587 ft-lb	81

** WARNING**

**If vibrator is mounted more than 6 in. (152 mm) above ground, install cable securing vibrator to structure. Without cable, vibrator could fall and cause injury.**

10. Secure vibrator to structure by installing MARTIN® BBAC Cable Kit, P/N 32271, or equivalent, as follows:
  - a. Weld D-ring onto structure wall above vibrator.
  - b. Loop 1/4-in. (6 mm) wire cable through vibrator handle and D-ring on structure wall.
  - c. Take up slack so cable is taut.
  - d. Apply thread sealing compound to nuts on cable clamps. Install four cable clamps (two on each) to secure cable to vibrator handle and D-ring. Torque cable clamps to 15-30 ft-lbs (2-4 kgm).
  - e. Trim loose ends of cable wire.

# After Installing Vibrator

---

## *Starting hydraulic vibrators*

### **⚠ WARNING**

Hydraulic oil under pressure can penetrate skin and result in injection poisoning. Special medical treatment is required for fluid injection injuries. If oil penetrates skin, see a doctor trained in fluid injection medicine immediately.

### **NOTE**

Make sure hydraulic system has a filtration system, and that oil is industrial petroleum-based oil, SAE 10 to 30, with wear, oxidation, and foaming inhibitors, and a viscosity of 200 SSU.

1. Make sure hydraulic hoses are secured to hydraulic pump.
2. Apply plastic sealing compound to all fittings.

### **⚠ CAUTION**

Avoid dropping disconnected hydraulic pump hoses where dirt or material can get in fittings.

Do not overtighten hydraulic hose fittings. If original position of fittings must be changed, end plate assembly, case, and motor assembly drive plate must be clamped together as a unit to prevent misalignment of plates. Misalignment of plates will cause motor damage. Contact Martin Engineering for further instructions.

Make sure inlet hose fitting is on inlet motor fitting, and outlet hose fitting is on outlet motor fitting. Motor seal failure will result if fittings are incorrectly installed.

Make sure inlet hose is same size as inlet motor fitting, and outlet hose is one size larger than outlet motor fitting and larger than inlet hose.

3. Place hydraulic hose fittings on back of vibrator motor. Place inlet hose fitting on inlet vibrator motor fitting, and outlet hose fitting on outlet vibrator motor fitting. Tighten fittings.

### **IMPORTANT**

Do not place flow-control valve on return line from motor. Return line must be free of restrictions or vibrator will not run correctly.

4. To control vibrator speed, place a flow-control valve on pressure side of motor.
5. Make sure hydraulic oil temperature does not exceed 150° F (65° C). (If oil temperature is above 150° F [65° C], a larger reservoir or heat exchanger on hydraulic pump may be required to allow better cooling. Consult Martin Engineering for instructions.)

*Starting  
pneumatic  
vibrators*

6. Start vibrator and operate using specifications in Appendix Table A-I or A-II as a guide.

**▲ CAUTION**

**Do not let inlet pressure exceed 1200 psi (82 bar). Seals will fail above 1200 psi (82 bar).**

**Remove pressure gauge after use. If pressure gauge is left on unit, gauge will be damaged.**

7. Use a pressure gauge to check both inlet and outlet pressure at vibrator. If inlet pressure exceeds 1200 psi (82 bar) or outlet pressure exceeds 30 psi (2 bar), check for restrictive fittings or increase hose size. If fittings are not restricted, remove pressure gauge.

**▲ WARNING**

**A WHIP-CHECK™ or equivalent (hose connection safety device) should be used on all air line connections to prevent personnel injury if air line should become uncoupled under pressure.**

**▲ CAUTION**

**Only filtered, regulated, and lubricated air can be used on BRUTE® Pneumatic Vibrators. Warranty will be void if air does not meet these requirements.**

**Handle air line with care. Do not allow air line to drop on ground or dirt to enter. Dirt will restrict air flow.**

1. Air line must be same diameter as inlet port diameter of vibrator motor. If air line is longer than 25 ft (7.62 m), use next diameter size air line.

**▲ CAUTION**

**Over-lubrication will restrict air flow and reduce vibrator operating speed. Under-lubrication will damage vibrator motor.**

**Use only MARTIN® Air Motor Oil (P/N 14766) with this vibrator. Using other oils can damage vibrator and will void warranty.**

2. Install air filter/regulator/lubricator on air line (see step 5 for cold weather instructions). Use MARTIN® Air Motor Oil only. Set lubricator to deliver 6 to 10 drops per minute.
3. Install BRUTE® Vibrator with WHIP-CHECK™ on air line.
4. If using muffler, remove cover plate from exhaust port and install muffler on vibrator motor exhaust port.

**⚠ CAUTION**

**Do not use BRUTE® Pneumatic Vibrators in temperatures below -25°F (-32°C).**

5. If using BRUTE® Pneumatic Vibrator in cold weather (to -25°F [-32°C]), do the following:
  - a. Use a 50/50 mix of MARTIN® Air Motor Oil and a nonflammable de-icing agent in lubricator. Set lubricator to deliver 6 to 10 drops per minute.
  - b. Install a second lubricator on air line between filter/regulator/lubricator and fill with a nonflammable de-icing agent to prevent condensation freezing. Set lubricator to deliver 1 to 3 drops per minute.

**⚠ CAUTION**

**Do not run vibrator over 80 psi (5.4 bar). Damage to vibrator will result.**

6. Start vibrator and operate according to specifications in Appendix, Table A-III.

**NOTE**

**Some BRUTE® Vibrators have adjustable eccentric weights. Weights are set at factory and this setting will serve for most applications. However, if adjustment is necessary, do so as instructed below.**

### *Adjusting eccentric weights*

**⚠ WARNING**

**Before adjusting eccentric weights, turn off and lock out/tag out energy source to vibrator.**

1. Turn off and lock out/tag out energy source to vibrator according to ANSI standards (see “References”).

**⚠ CAUTION**

**Adjust both sets of eccentric weights to same setting number (mirror images), or force output will be uneven and damage vibrator.**

2. Remove screws from back cover and pry cover from case.
3. If applicable, remove motor/flange to adjust weights on motor side of vibrator. (CV2.0 units have only one adjustable weight on back side of unit.) Remove motor/flange as follows:
  - a. See Figure 5. Remove six 1-in. (25 mm) long hex head cap screws (A) from motor side of unit.

- b. Loosen four motor screws (B) one turn.
- c. If motor assembly (C) is tightly engaged with case (D), remove the two 1/4-in. (6 mm) long hex head cap screws and replace them with two of the 1-in. (25 mm) long hex head cap screws removed in step 3.a.
- d. Evenly turn the two screws to push the motor flange away from the case. (If shaft is still not free, use two 1/4 -20 NC hex head cap screws that are 2-1/2 in. (64 mm) long.

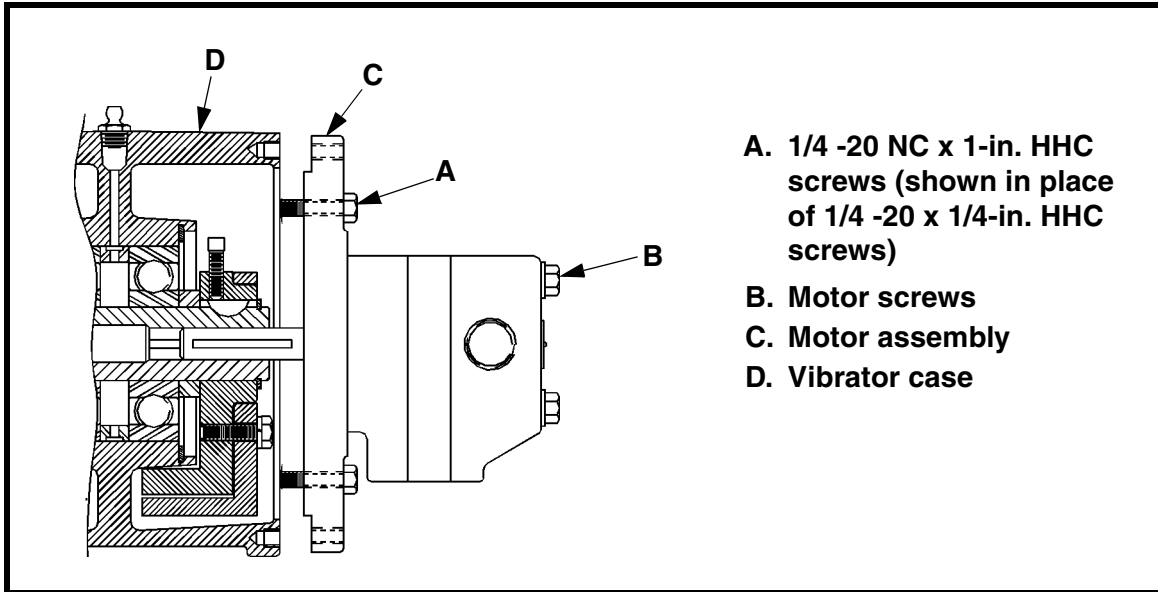

**Figure 5. Removing Motor/Flange Assembly**

4. Set adjustable eccentric weight as follows:
  - a. Remove hex head cap screw and lock washer from adjustable eccentric weight.
  - b. See Figure 6. Rotate adjustable eccentric weight to proper setting according to Appendix. Move weight to higher number to produce less force (i.e., highest number is minimum setting and lowest number is maximum setting).

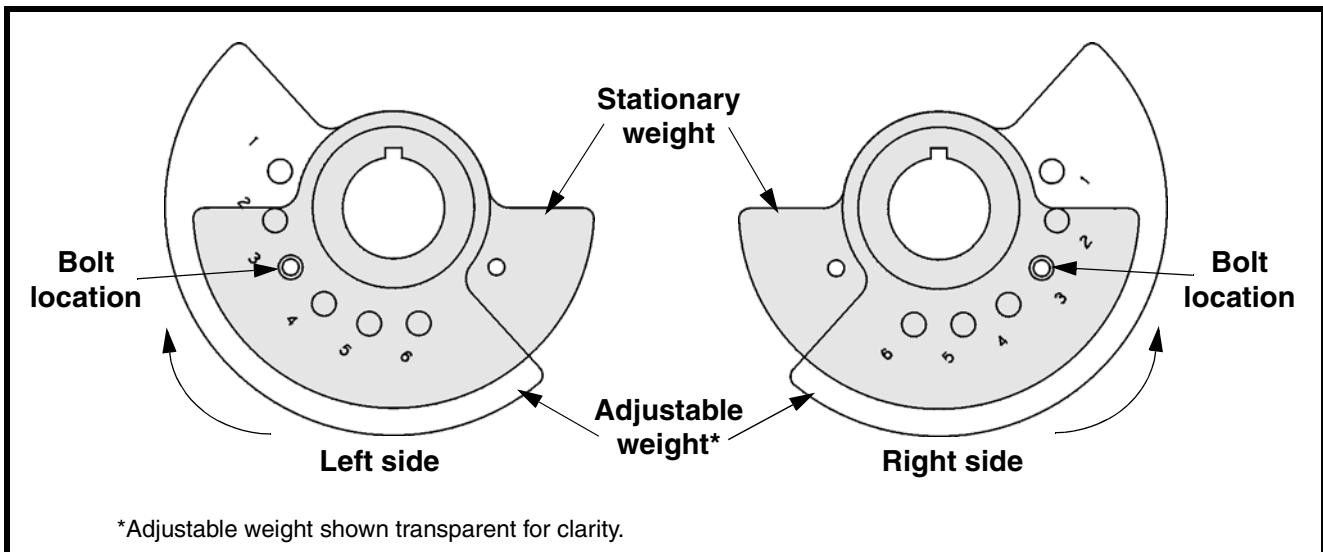

**Figure 6. Eccentric Weight Settings**

- c. Install hex head cap screw and lock washer through desired setting hole and into same hole on stationary weight bolt was removed from in step 4.a. Tighten to 8 ft-lb (1 kgm).

**⚠ CAUTION**

**Adjust both sets of eccentric weights to same setting number (mirror images), or force output will be uneven and damage vibrator.**

- d. Repeat steps 4.a through 4.c for second set of weights. Set both sets of weights to same setting number so they are mirror images.
5. Apply teflon tape to screws, and install back cover and screws.

**⚠ CAUTION**

**Feather key must not come out of shaft when reinstalling motor. Shaft and key should assemble with little or no pressure. If key is displaced when reassembling, vibrator will be damaged.**

6. Remove longer hex head cap screws from motor assembly and reinstall onto case.
7. Replace six 1-in. (25 mm) long screws and two 1/4-in. (6 mm) long screws and torque 8 to 10 ft-lb (1 to 1.4 kgm).
8. Torque four motor screws 8 to 10 ft-lb (1 to 1.4 kgm).

# Troubleshooting

---

## *Hydraulic vibrators*

Symptom	Corrective action
Gallons-per-minute flow to vibrator is less than required (see Table A-I and A-II).	Outlet hose is too small. Make sure outlet hose is one size larger than outlet motor fitting.

## *Pneumatic vibrators*

Symptom	Corrective action
Vibrator will not reach required speed or exceeds psi rating.	<ul style="list-style-type: none"> <li>• Vibrator is receiving too much or too little lubrication. Reset lubricator to deliver 6 to 10 drops per minute.</li> <li>• Air filter is clogged. Clean or replace air filter.</li> <li>• Air line from compressor to vibrator is too small for cfm requirements. Check valves, gauges, and air line diameter. Replace with bigger air line.</li> <li>• Air line is restricted or leaking. Replace or repair air line.</li> <li>• Regulator is faulty or leaking. Replace or repair regulator.</li> <li>• Compressor is not delivering required cfm. Replace with larger compressor.</li> <li>• Muffler is clogged. Clean or replace muffler.</li> </ul>

## *Hydraulic vibrators*

### **⚠ WARNING**

Hydraulic oil under pressure can penetrate skin and result in injection poisoning. Special medical treatment is required for fluid injection injuries. If oil penetrates skin, see a doctor trained in fluid injection medicine immediately.

1. Use cardboard to inspect hoses and fittings for leaks.
2. Inspect oil. If dark or thick, replace.

### **⚠ CAUTION**

Do not overtighten hydraulic hose fittings. Damage to fittings and motor will result.

3. Make sure all fasteners are tight.
4. Inspect structure for cracks or fatigue. If found, repair before operating vibrator again.

## *Pneumatic vibrators*

1. Inspect air filter in hose whip filter assembly for dirt. If dirty, clean or replace filter.
2. Inspect air line filter for dirt. If dirty, clean or replace filter.
3. If using a muffler, clean muffler with industrial solvent.
4. Inspect air line from compressor to vibrator and all connections for leaks, dirt, or damage. Clean or replace as necessary.
5. Make sure lubricator(s) are filled and delivering 6 to 10 drops per minute.
6. Make sure all fasteners are tight.
7. Inspect structure for cracks or fatigue. If found, repair before operating vibrator again.

### **NOTE**

## *Clamp foot parts replacement (CCV units)*

Thread sealing compound has been applied to hex head set screw and bushings. You may need to heat clamp feet to 300°F (149°C) to release bond of thread sealing compound.

1. Remove hex head set screw and both bushings. If necessary, apply heat to clamp feet.
2. Remove all thread sealing compound from threads of hex head set screw and both bushings.
3. Inspect parts for wear. If worn, discard old parts and replace as follows:
  - a. Apply thread sealing compound to threads of hex head set screw and both bushings.
  - b. Install static bushing in back side of unit. Tighten to 250 ft-lb (35 kgm) for all CCV units.

*Lubrication*

- c. Install clamp block bushing in motor side of unit. Tighten to 250 ft-lb (35 kgm) for all CCV units.
- d. Install hex head set screw in motor side of unit. Tighten to 250 ft-lb (35 kgm) for CCV4 units and 450 ft-lb (62 kgm) for CCV6 units.

**NOTE**

**All models containing a suffix letter G have greased bearings. All other models have oil bath bearings. Lubrication for each unit type is explained below.**

***Oil bath units***

Oil bath units require oil changes after every 500 hours of operation. Use 3/4 oz. MOBIL 1 SAE 5W-30 oil in 4-case motors. Use 1-1/4 oz. MOBIL 630 oil in 6-case motors. Replace oil as follows:

1. Turn off and lock out/tag out energy source from vibrator according to ANSI standards (see “References”).
2. See Figure 15, 16, 17, or 18. Remove square head pipe plug from case.
3. Drain oil from case.
4. Flush bearings with new oil and drain. Repeat twice. Drain completely.

**NOTE**

**Place vibrator at an upward angle or oil will leak from unit. Do not stand vibrator up.**

5. Set vibrator so oil will not leak out when poured in.
6. While rotating shaft by hand, put .50 fluid oz (15 cc) of oil in bearings for 2.8 cases, .75 fluid oz (22 cc) in bearings for 4 cases, or 1.25 oz (37 cc) in bearings for 6 cases.
7. Replace square head pipe plug.

***Greased units***

Using MARTIN® Grease (P/N 16994) or equivalent rated for -65°F (-18°C) to +350°F (177°C), lubricate units as follows:

1. Turn off and lock out/tag out any energy source from vibrator according to ANSI standards (see “References”). Disconnect all hoses from air or hydraulic source.
2. Remove plastic cap (if present) from grease fitting.

**⚠ CAUTION**

**Do not over-lubricate vibrator. Over-lubrication can cause premature bearing failure.**

3. Lubricate CV2.0 vibrators every 500 hours of operation with .125 oz of grease in grease fitting.
4. Lubricate CC2.8, CV2.8, CCV4, and DV4 vibrators every 500 hours of operation with .25 oz of grease in grease fitting.
5. Lubricate CCV6 and DV6 vibrators every 500 hours of operation with .50 oz of grease in grease fitting.

## ***Replacing air motor vane***

1. See Figure 11. Remove hex head cap screw (13) and retaining ring (12).
2. Screw 3/8 by 2-in. bolt into hole on top of dead end plate (10) until plate is out of air motor body (1).
3. Remove old vanes (15).



**When cleaning vane/rotor area, do not remove rotor (9).**

4. Clean vane/rotor area. Do not remove rotor.
5. Lightly oil new vanes with MARTIN® Air Motor Oil (P/N 14766) and install vanes.
6. Install dead end plate so o-ring (11) is aligned with hole A in stator.
7. Lightly tap on dead end plate until seated.
8. Install retaining ring. Lightly tap until seated.
9. Place 1 cc of MARTIN® Air Motor Oil in inlet and rotate shaft.
10. Install hex head cap screws and tighten.

## Notes

## Part Numbers

This section provides part numbers for BRUTE® Vibrators and related equipment. Please reference part numbers when ordering parts. Refer to Figures 7 through 11 for motor part numbers and 12 through 18 for case part numbers.

### **▲ CAUTION**

**All BRUTE® Vibrator motors must be returned to Martin Engineering for warranty motor repair. Warranty will be void if vibrator is returned disassembled while under warranty.**

Assembly part no.	Case assembly part no.	Case model	Motor part no.	Motor model/type	Bearing type
32005	N/A	CV2.0	18484	2HB Hydraulic	Greased
29763	29752	CV2.8	27873	2A Air	
29765	29752	CV2.8	12959	5 HB Hydraulic	
29762	29756	CC2.8	27873	2A Air	
29759	29756	CC2.8	12959	5 HB Hydraulic	
29768	29751	DV4	12959	5 HB Hydraulic	
29771	29751	DV4	27873	2A Air	
29773	29755	CCV4	27873	2A Air	
29775	29755	CCV4	12959	5 HB Hydraulic	
18113-XX	24378	DV6	27874	6A Air	
18137-XX	24378	DV6	12965	8HA Hydraulic	
14716-XX	24377	CCV6	27874	6A Air	
29766	29754	DV4	12959	5HB Hydraulic	
29774	29754	DV4	27873	2A Air	
29758	29753	CCV4	12959	5 HB Hydraulic	
29769	29753	CCV4	27873	2A Air	
22110-XX	22081	DV6	27874	6A Air	
22111-XX	22081	DV6	12965	8HA Hydraulic	
22107-XX	22080	CCV6	27874	6A Air	
22108-XX	22080	CCV6	12965	8HA Hydraulic	

**NOTE**

If specific mounts are not listed for your BRUTE® Vibrator, contact Martin Engineering for assistance in selecting a mount.

***Mounts***

**Clamp blocks for CV2.0:** P/N 12958-03.

**Clamp blocks for CV2.8:** P/N 12958-05.

**Cradle Lug Bracket:** P/N 28732.

**LBM - LBF Mount:** LBM P/N 10087, LBF P/N 12735. (LBF is female half of railroad car vibrator wedge and can be welded or bolted onto structure. LBM is male half of wedge.)

***Repair kits for air motors***

**2A Dead end:** P/N 33205.

**2A Live end:** P/N 33206.

**6A Dead end:** P/N 33207.

**6A Live end:** P/N 33208.

***Miscellaneous***

**MARTIN® Air Motor Oil:** P/N 14766 (one quart), P/N 14767 (case).

**MARTIN® Grease:** P/N 16944.

**MARTIN® WHIP-CHECK™ for 1/4-in. Air Line:** P/N 20630.

**3/4-in. hose whip assembly:** P/N 17971.

**1/2-in. hose whip assembly:** P/N 17970.

**BBAC Cable Kit:** P/N 32271. (Kit includes D-ring, cable, cable clamps, and clamp hardware.)

**Muffler for 3/4-in. Air:** P/N 19665

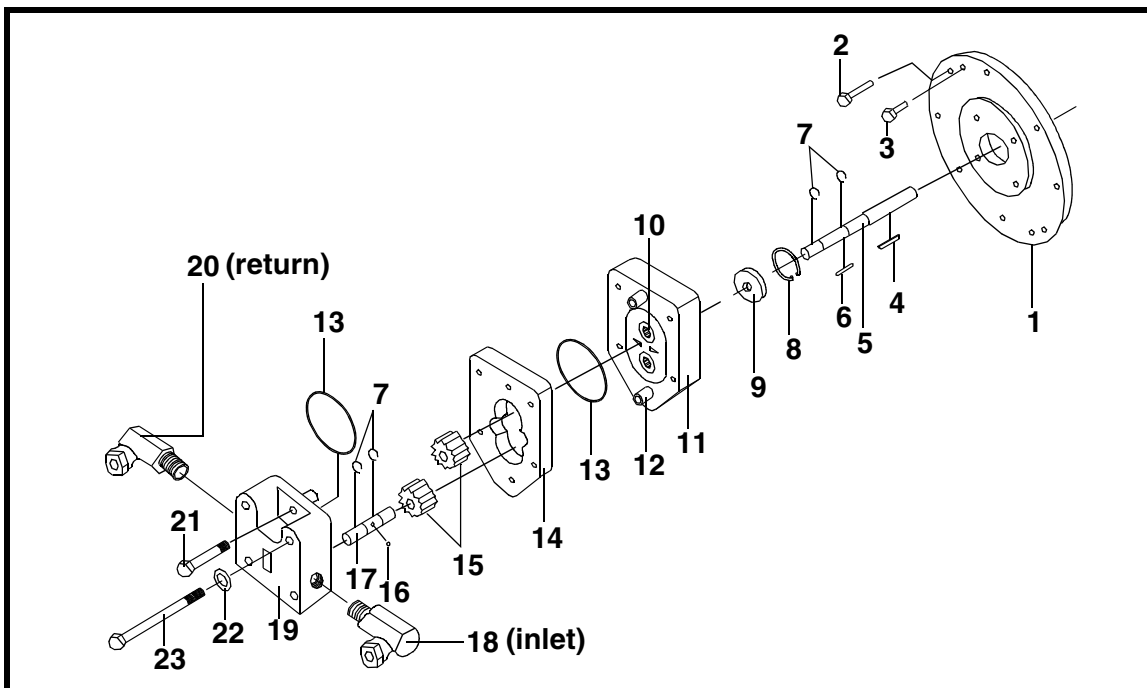

Item	Description	Part no.	Qty
1	Motor flange	12957	1
2	1/4" -20 NC x 1" hex head cap screw	12699	6
3	1/4"-20NC x 1/4" hex head cap screw	31428	2
4	1-1/2" large feather key	12846	1
5	Drive shaft	13457	1
6	Dowel key	13458	1
7	Retaining ring	13472	4
8	Retaining ring	13459	1
9	Seal assembly	14860	1
10	Bearing	13464	4
11	Motor assembly drive plate	15856	1
12	Dowel pin	14038	2
13	O-ring	13465	2
14	Case	13463	1
15	Gear	13467	2
16	Ball	13468	1
17	Idler shaft	13469	1
18	90° Male adapter union (inlet)	13368	1
19	End plate assembly	15857	1
20	90° Male adapter union (return)	13387	1
21	1/4" -20 NC x 1-3/4" hex head cap screw	13471	2
22	21/64" compression washer	11452	4
23	5/16" -18 NC x 3-3/4" hex head cap screw	12694	4
NS	5HB Motor	12876	1

Figure 7. 5HB Hydraulic Motor Assembly, P/N 12959



Item	Description	Part no.	Qty
1	Motor flange	31832*	1
		12957**	1
2	Screw HHC 1/4 -20 NC x 7/8	11891*	4
	Screw HHC 1/4 -20 NC x 1	12699**	6
3	Retaining ring	13459	1
4	Seal retainer	31011-14	1
5	Oil seal	31011-26	1
6	Washer	31011-28	1
7	Key	12846	1
8	Drive shaft	31011-19	1
9	Dowel key	31011-20	1
10	Bearing	19626	1
11	Snap ring	31011-22	1
12	Plug	31011-18	2
13	O-ring	31011-13	1
14	Spring	31011-15	1
15	Steel ball	31011-11	1
16	O-ring	31011-17	1
17	Drive Plate	31011-09	1
18	Dowel Pins	31011-08	2
19	Bearing	13464	4
20	O-ring	31011-06	2
21	Motor case	31011-02	1
22	Idler and drive gear	31011-03	2
23	Retaining ring	13472	2
24	Ball	31011-07	1
25	Idler shaft	31011-04	1
26	End plate	31011-16	1
27	5/16 -18 NC x 3-1/4 HHCS	12692	2
28	5/16 Compression washer	11452	4
29	Hydraulic motor fitting	31219	2
30	5/16 -18NC x 3-3/4 HHCS	30829	4
NS	1/4 -20NC -2A x 1/4 HHCS	31428	2
NS	Motor 2 HB Hydraulic	18776	1

**Figure 8. 2HB Hydraulic Motor Assembly, P/N 18484 (sheet 2 of 2)**

\*Part number for MINI-BRUTE™ assembly (CV2.0).

\*\*Part number for CV2.8 assembly.

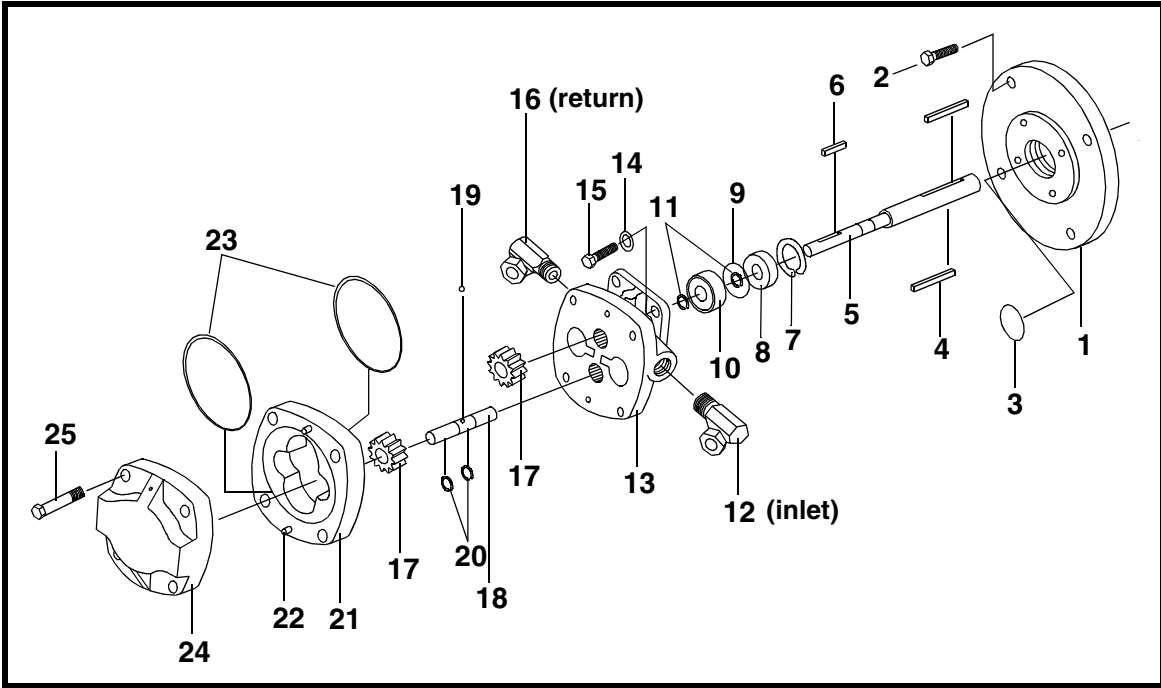

Figure 9. 8HA Hydraulic Motor Assembly, P/N 12965 (sheet 1 of 2)

Item	Description	Part no.	Qty
1	Motor flange	12967	1
2	3/8" -16 NC x 1-1/4" Hex head cap screw	12215	4
3	O-ring	11639	1
4	2-1/2" Large feather key	11869	2
5	Drive shaft	13473	1
6	Dowel key	13474	1
7	Snap ring	13478	1
8	Motor shaft seal	25954	1
9	Shaft spacer	25977	1
10	Bearing	13479	1
11	Retaining ring	13491	2
12	90° Male adapter union (inlet) 1/2 NPSM/ 12 NPT	13368	1
13	Motor assembly drive plate	15858	1
14	21/64" I.D. compression washer	11452	4
15	5/16" -18 NC x 1" Hex head cap screw	11991	4
16	90° Male adapter union (return) 3/4 NPSM/ 12 NPT	13387	1
17	Gear	13485	2
18	Idler shaft	13483	1
19	Ball	13484	1
20	Retaining ring	13480	2
21	Case	13486	1
22	Dowel pin	14039	2
23	O-ring	13487	1
24	End plate assembly	15859	1
25	3/8" -16 NC x 2" Hex head cap screw	13489	4
NS	8HA Motor (items 5 through 10, 13, 17 through 22, and 24)	26020	1

**Figure 9. 8HA Hydraulic Motor Assembly, P/N 12965 (sheet 2 of 2)**

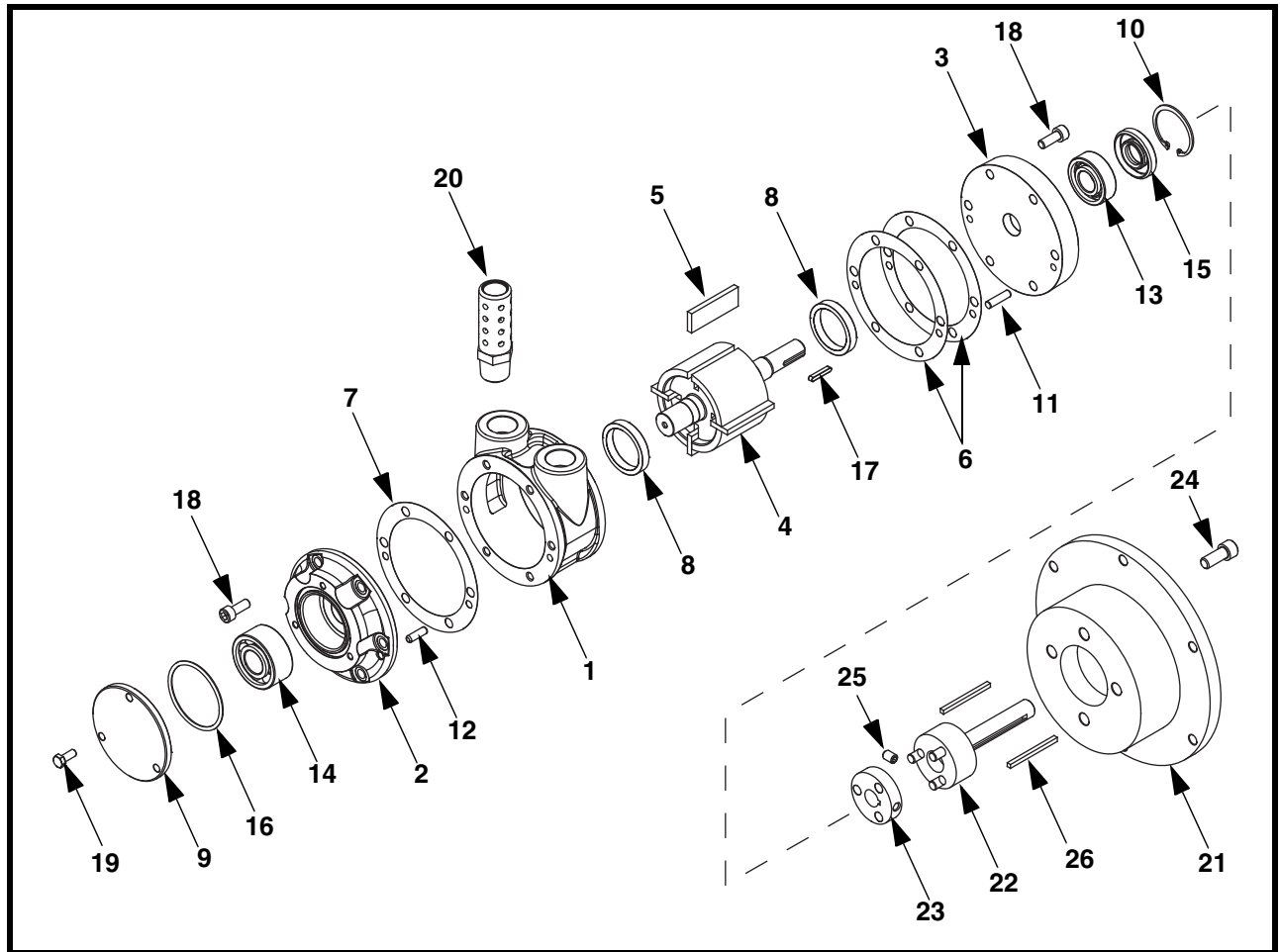
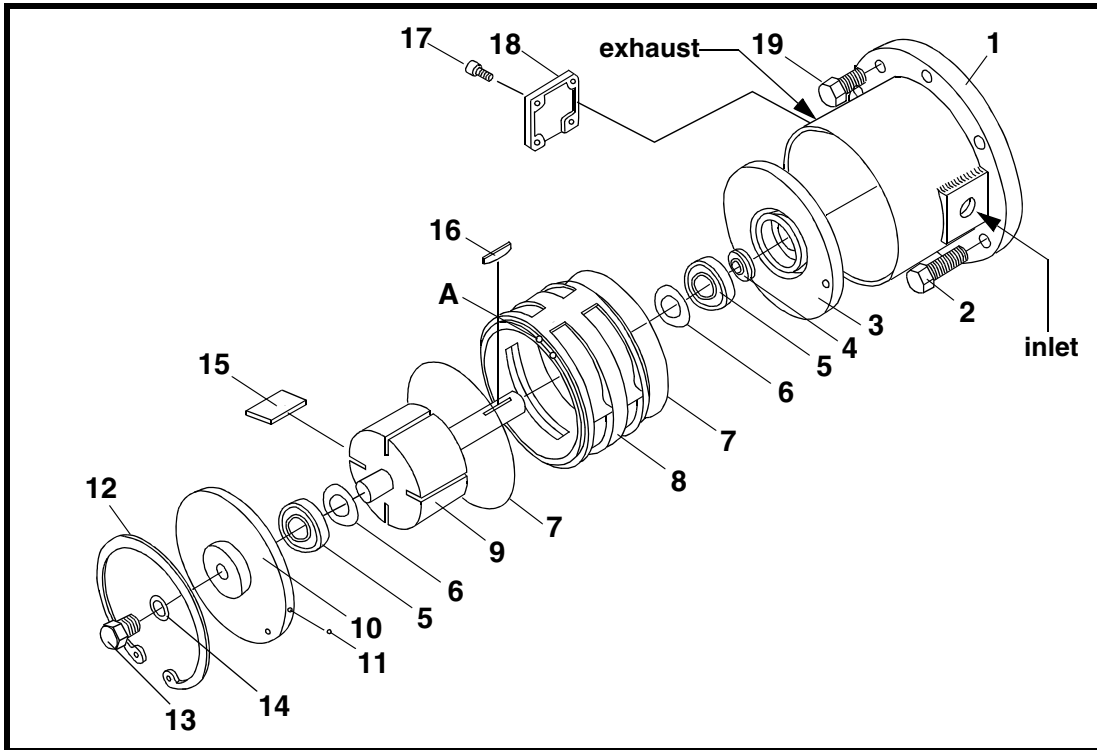

Figure 10. 2A Air Motor Assembly, P/N 27873 (sheet 1 of 2)

Item	Description	Part no.	Qty
1	Body	210338	1
2	Front Plate	210339	1
3	End Plate	210340	1
4	Rotor	210341	1
5	Vane	210342	4
6	Gasket – Red	210343	2
7	Gasket – Green	210344	1
8	Ejection Ring	210345	2
9	Cover Plate	210346	1
10	Snap Ring	210347	1
11	Dowel Pin	210348	2
12	Dowel Pin	210349	2
13	Bearing	210350	1
14	Bearing	210351	1
15	Oil Seal	210352	1
16	O-Ring	210353	1
17	Key Rnd 1/8 x 1/8 x 3/4	210354	1
18	Screw SHC M6–1.0mm x 16mm PF	210356	12
19	Screw HHC M5–0.8mm x 12mm ZP	210355	3
20	Muffler	210317	1
21	Face Plate	120161	1
22	Drive Shaft	150329	1
23	Drive Ring	170526	1
24	Screw SHC 5/16-18 x 3/4	501244	4
25	Screw Socket Set CP 1/4-20NC x 3/8	519884	1
26	Key 1/8 x 1/8 x 1-3/4	520807	2

**Figure 10. 2A Air Motor Assembly, P/N 27873 (sheet 2 of 2)**



**Figure 11. Air Motor Assemblies, P/Ns 27874 (6A) or 11257 (6A) with springs and push pins included (sheet 1 of 2)**

	<b>6A</b>
Exhaust	1 - 11-1/2 NPT
Inlet	3/4 - 14 NPT

Item	Description	6A Part no.	6A With springs and push pins	Qty
1	Air motor body	10924	10924	1
2	1/4" -20NC -2A x 3/4" HHC screw	N/A	N/A	6
2	3/8" -16NC x 1-1/2" SHC screw	11877	11877	4
3	Live end plate	33306	33306	1
4	Shaft seal	11873	11873	1
5	Bearing	26630	26630	2
6	Spacer	32926-01	32926-01	2
7	3-3/4" x 3-1/2" O-ring	N/A	N/A	2
7	4-5/8" x 4-3/8" O-ring	11859	11859	2
8	Stator	26587	26587	1
9	Rotor	26683	11211	1
10	Dead end plate	33304	33304	1
11	1/2" x 3/8" O-ring	12017	12017	1
12	Retaining ring	11860	11860	1
13	3/8" -16 x 3/8" HHC screw	12518	12518	1
14	3/8" Fiber washer	11854	11854	1
15	Vane (UHMW/Phenolic)	29750/ 27866	22862	4
16	2" Large feather key	11869	11869	2
17	#10 -24 x 3/4" Square head cap screw	N/A	N/A	4
17	#10 -24 NC x 1" Square head cap screw	11872	11872	4
18	Exhaust cap	11049	11049	1
19	1/4"-20NC-2A x1/4" HHC screw	N/A	N/A	2
NS	Vane spring	N/A	13180	4
NS	Vane pin	N/A	11344	2
Fig. 18	Air motor caution label	22765	22765	1

**Figure 11. Air Motor Assemblies, P/Ns 27874 (6A) or 11257 (6A) with springs and push pins included (sheet 2 of 2)**

# Part Numbers

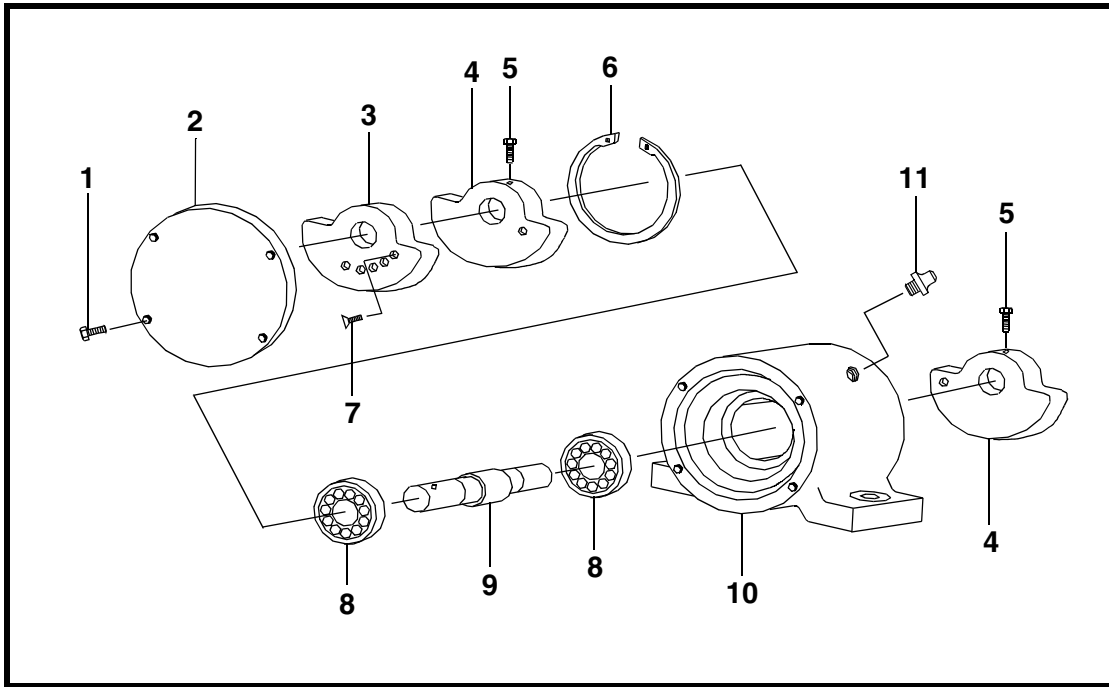

Item	Description	Part no.	Qty
1	1/4 -20 NC x 7/8 HHCS	11891	8
2	Back cap	31813	1
3	Adjustable weight	31792	1
4	Stationary weight	31791	2
5	#8 -32 NC x 3/4 HHCS	31892	2
6	Retaining ring	12853	1
7	1/4 -20 NC x 3/4 SHCS	30453	1
8	Ball bearing	14864	2
9	Eccentric shaft	31793	1
10	Case	31811	1
11	1/8 -27 NPT Grease fitting	11814	1
NS	1/4 -20 NC -2A x 1/4 Lg HHCS	31428	2
NS	Lube strap cap	12533	1
NS	MINI-BRUTE™ Label Kit	33887-M	1

**Figure 12. CV2.0 Case Assembly (greased)**

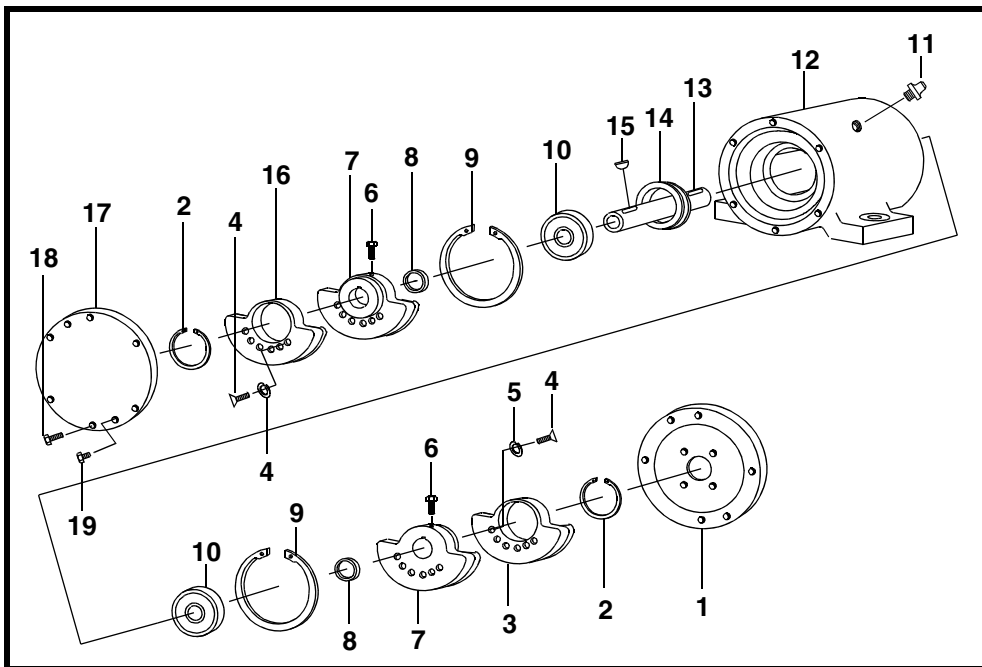

Item	Description	Part no.	Qty
1	Motor flange	31782	1
2	Retaining ring	16349	2
3	Adjustable eccentric weight (right)	29749	1
4	1/4" - 20 NC x 3/4" Hex head cap screw	11891	2
5	1/4" Split lock washer	11894	2
6	1/4"-20 NC x 3/4" Square head set screw	11745-01	2
7	Stationary eccentric weight (right)	29744-02	2
8	Eccentric spacer	16352	2
9	Internal retaining ring	16071	2
10	Bearing	16070	2
11	1/8" -27 NPT grease fitting	11814	1
12	CV2.8G case	17497	1
13	Eccentric shaft	16417	1
14	Bearing spacer	16354	1
15	Eccentric key	16345	2
16	Adjustable eccentric weight (left)	29749-01	1
17	Back cover	17896	1
18	1/4" - 20 NC -2A x 3/4" Hex head cap screw	11852	12
19	1/4" - 20 NC -2A x 1/4" Hex head cap screw	31428	4
NS	3/4" Compression washer	11754	2
NS	1/4" - 20 NC x 1" Hex head cap screw	12699	6

Figure 13. CV2.8 Case Assembly, P/N 29752

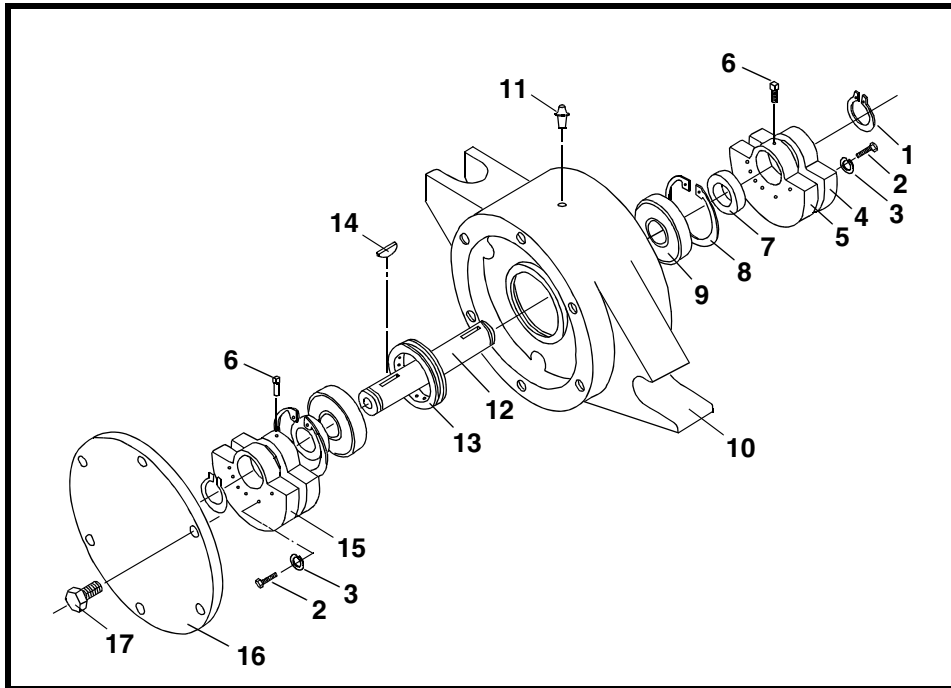

Item	Description	Part no.	Qty
1	Retaining ring	16349	2
2	1/4"-20 NC x 3/4" Hex head cap screw	11891	2
3	1/4" Split lock washer	11894	2
4	Adjustable eccentric weight	29749	1
5	Stationary eccentric weight	29744-02	2
6	1/4" -20 NC x 3/4" Square head set screw	11745-01	2
7	Eccentric spacer	16352	2
8	Internal retaining ring	16071	2
9	Bearing	16070	2
10	CC2.8 case	18030	1
11	1/8"-27 NPT grease fitting	11814	1
12	Eccentric shaft	16417	1
13	Bearing spacer	16354	1
14	Eccentric key	16345	2
15	Adjustable eccentric weight (left)	29749-01	1
16	Back cover	17896	1
17	1/4" -20 NC -2A x 3/4" Hex head cap screw	11852	6
NS	Lube strap cap	12533	1

Figure 14. CC2.8 Case Assembly, P/N 29756

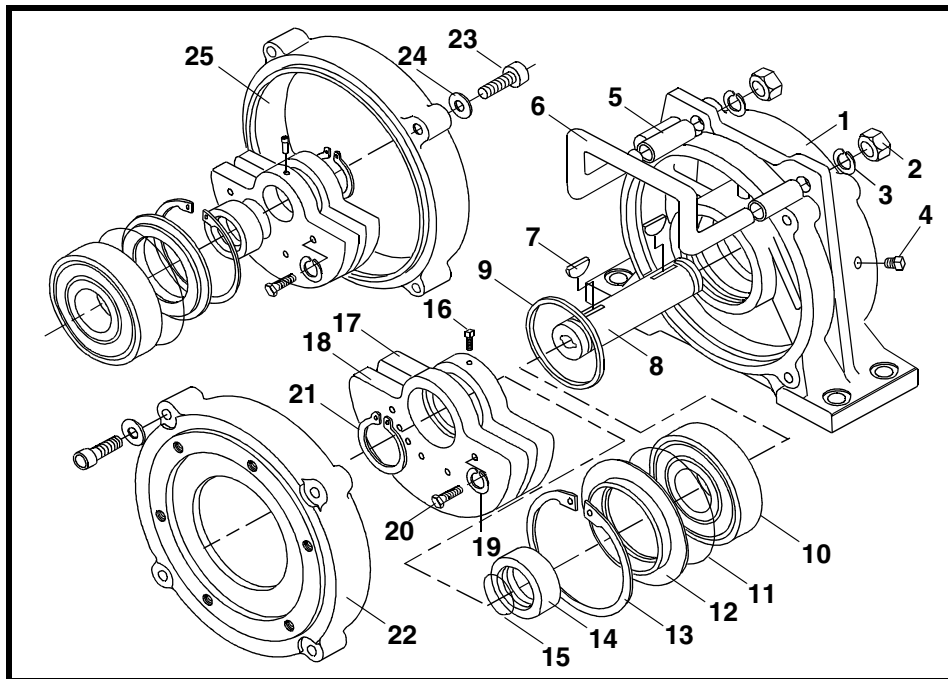

Item	Description	DV4 w/oil bath bearings	DV4 w/greased bearings	Qty
1	DV4S/DV4G Case	22242	22242	1
2	1/2" -13NC -2B Cad plated hex nut	11771	11771	2
3	1/2" Lock washer	17329	17329	2
4	Square head pipe plug	12400	12400	2/1
5	Handle bushing	12864	12864	2
6	Handle	12858	12858	1
7	Eccentric key	16345	16345	2
8	Eccentric shaft	16417	16417	1
9	Bearing spacer	22067	22067	1
10	Bearing	16070	16070	2
11	O-ring	22065	N/A	2
12	Seal retainer	22066	N/A	2
13	Internal retaining ring	22063	N/A	2
14	Eccentric spacer	22061	31659	2
15	O-ring	22062	N/A	2
16	1/4" - 20 NC x 3/4" Square head set screw	11745-01	11745-01	2
17	Inner eccentric weight (stationary)	29747-01	29747-01	2
18	Outer eccentric weight (adjustable)	29748	29748	2
19	1/4" Split lock washer	11894	11894	2
20	1/4" - 20 NC x 3/4" HHC screw	11891	11891	2
21	Retaining ring	16349	16349	2
22	Motor flange	16061	16061	1
23	3/8" -16NC x 1-1/2" SHC screw	11877	11877	8
24	3/4" Compression washer	11747	11747	8
25	Back cover	16063	16063	1
NS	Grease fitting	N/A	11814	1
NS	Lube strap cap	N/A	12533	1

**Figure 15. DV4 Case Assemblies, P/N 29751 (greased) or 29754 (oil bath)**

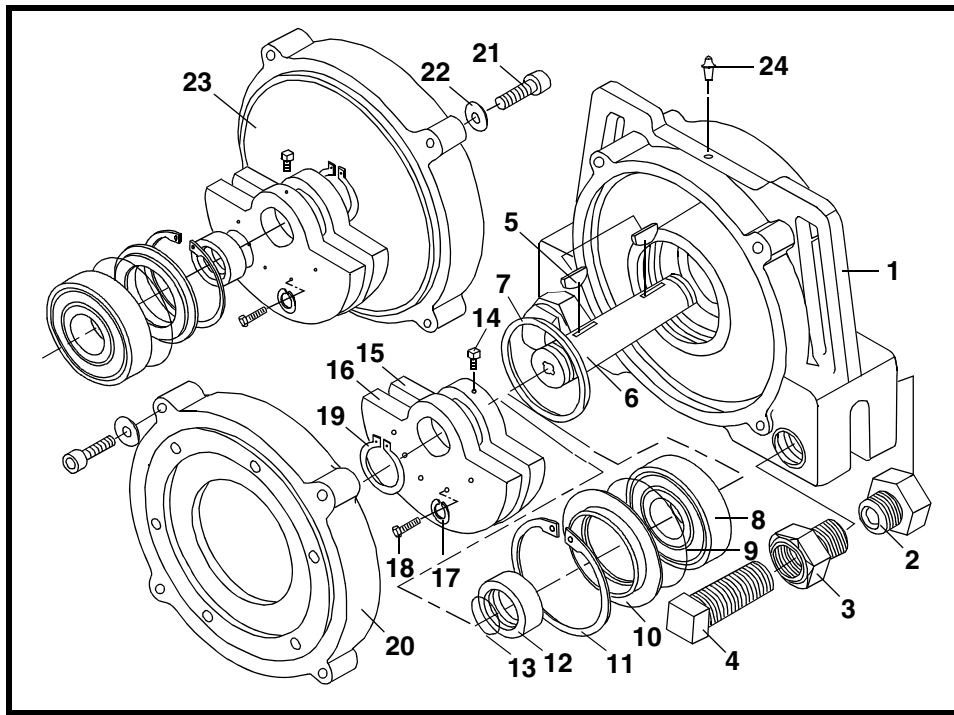

Item	Description	CCV4 w/oil bath bearings	CCV4 w/greased bearings	Qty
1	CCV4S/CCV4G Case	22068	22068	1
2	Static jaw	12719	12719	2
3	Clamp block bushing	12257	12257	2
4	1" -12 UNF -2A HHC screw	31318-01	31318-01	2
5	Eccentric key	16345	16345	2
6	Eccentric shaft	16417	16417	1
7	Bearing spacer	22067	22067	1
8	Bearing	16070	16070	2
9	O-ring	22065	N/A	2
10	Seal retainer	22066	N/A	2
11	Internal retaining ring	22063	N/A	2
12	Eccentric spacer	22061	31659	2
13	O-ring	22062	N/A	2
14	1/4" - 20 NC x 3/4" Square head set screw	11745-01	11745-01	2
15	Inner eccentric weight (stationary)	29747-01	29747-01	2
16	Outer eccentric weight (adjustable)	29748	29748	2
17	1/4" Split lock washer	11894	11894	2
18	1/4" - 20 NC x 3/4" HHC screw	11891	11891	2
19	Retaining ring	16349	16349	2
20	Motor flange	16061	16061	1
21	3/8" -16NC x 1-1/2" SHC screw	11877	11877	8
22	3/4" Compression washer	11747	11747	8
23	Back cover	16063	16063	1
24	Grease fitting	N/A	11814	1
NS	Square head pipe plug	12400	N/A	1
NS	Lube strap cap	N/A	12533	1
NS	Oil seal	22064	N/A	2

Figure 16. CCV4 Case Assemblies, P/N's 29755 or 29773 (greased) or 22024 (oil bath)

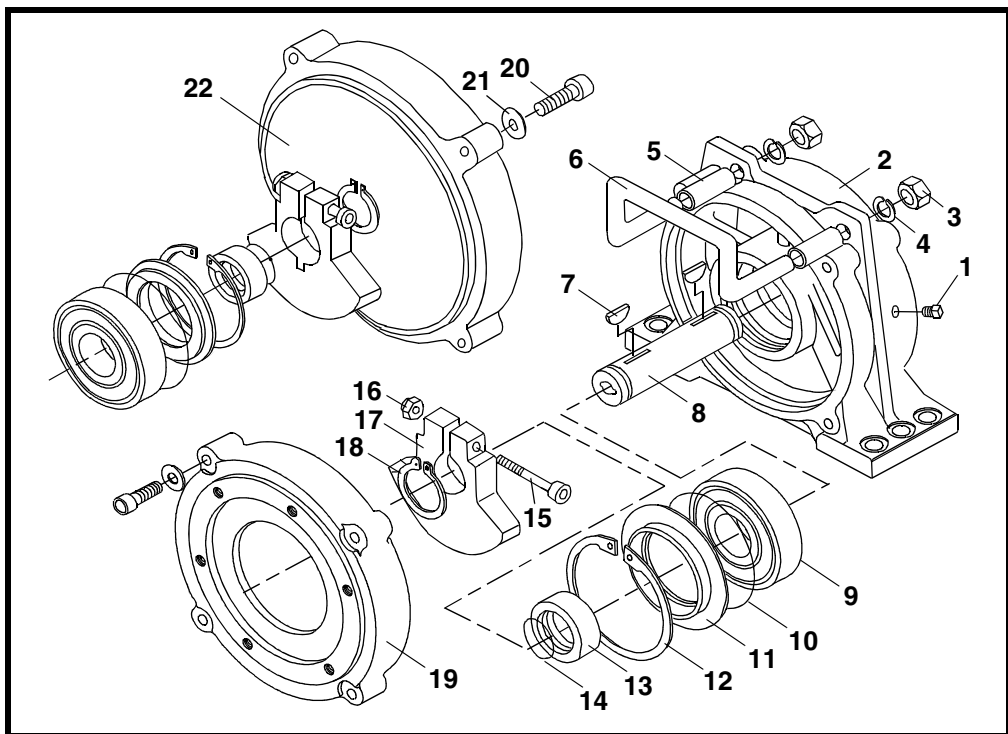

Item	Description	DV6 w/oil bath bearings	DV6 w/greased bearings	Qty
1	Square head pipe plug	12400	12400	2/1
2	DV6S/DV6G Case	22092	22092	1
3	1/2" -13 NC -2B Cad plated nut	11771	11771	2
4	1/2" Lockwasher	17329	17329	2
5	Handle bushing	13255	13255	2
6	Handle	10344	10344	1
7	Eccentric key	16345	16345	2
8	Eccentric shaft	22090	22090	1
9	Bearing	24021	11862	2
10	O-ring	22085	N/A	2
11	Seal retainer	25768	25768	2
12	Retaining ring	22230	22230	2
13	Eccentric spacer	22089	31660	2
14	O-ring	22084	22084	2
15	3/8" - 16 NC x 3-1/2" SHC screw	12922	12922	2
16	3/8" -16 NC stop nut	14201	14201	2
17	Eccentric weight (6 lb)	18013	18013	2
	Eccentric weight (12.5 lb)	17046	17046	2
	Eccentric weight (17.5 lb)	16275	16275	2
	Eccentric weight (25 lb)	21689	21689	2
18	Retaining ring	12569	12569	2
19	Motor flange	13166	13166	1
20	3/8" -16NC x 2-1/4" SHC screw	13256	13256	8
21	3/8" Compression washer	11747	11747	8
22	Back cover	13168	13168	1
NS	Grease fitting	N/A	11814	1
NS	Lube strap cap	N/A	12533	1

**Figure 17. DV6 Case Assemblies P/N 22081-XX\***

\*See Table IV.

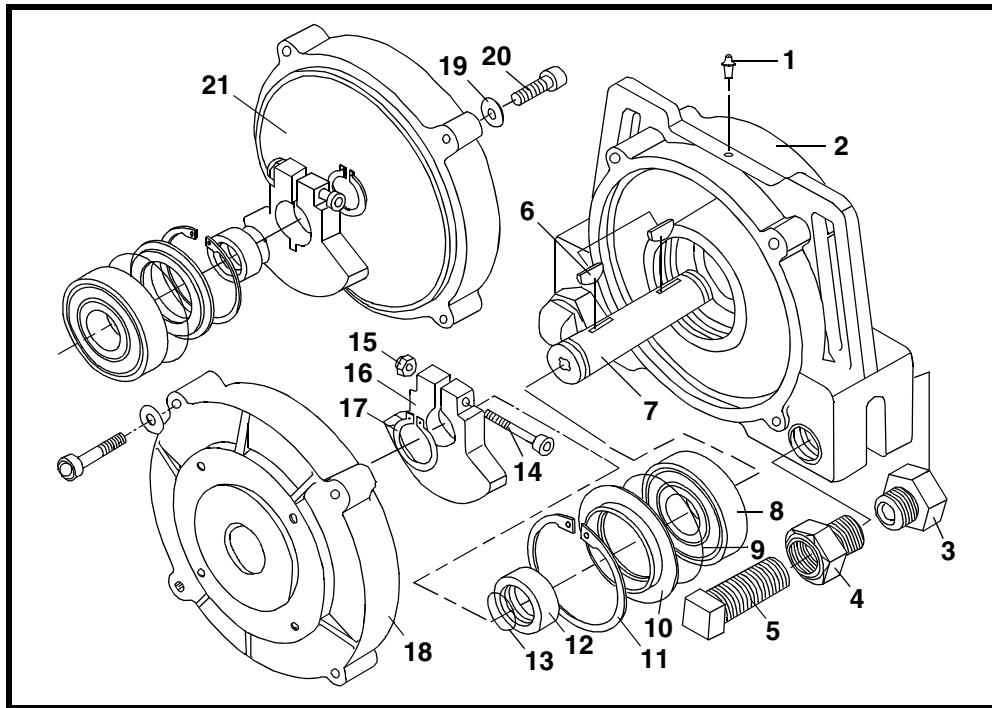

Item	Description	CCV6 w/oil bath bearings	CCV6 w/greased bearings	Qty
1	Grease fitting	N/A	11814	1
2	CCV6S Case	22091	24383	1
3	Static jaw	12719	12719	2
4	Clamp block bushing	12257	12257	2
5	1" -12 UNF -2A HHC screw	31318-01	31318-01	2
6	Eccentric key	16345	16345	2
7	Eccentric shaft	22090	22090	1
8	Bearing	24021	11862	2
9	O-ring	22085	N/A	2
10	Seal retainer	25768	25768	2
11	Retaining ring	22230	22230	2
12	Eccentric spacer	22089	31660	2
13	O-ring	22084	22084	2
14	3/8" - 16 NC x 3-1/2" SHC screw	12922	12922	2
15	3/8" -16 NC stop nut	14201	14201	2
16	Eccentric weight (6 lb)	18013	18013	2
	Eccentric weight (12.5 lb)	17046	17046	2
	Eccentric weight (17.5 lb)	16275	16275	2
	Eccentric weight (25 lb)	21689	21689	2
17	Retaining ring	12569	12569	2
18	Motor flange	13166	13166	1
19	3/8" Compression washer	11747	11747	8
20	3/8" -16NC x 2-1/4" SHC screw	13256	13256	8
21	Back cover	13168	13168	1
NS	Shaft seal	22086	22086	2
NS	Square head pipe plug	12400	N/A	1
NS	Lube strap cap	N/A	12533	1

Figure 18. CCV6 Case Assemblies P/Ns 24377-XX\* (greased) or 22080-XX\* (oil bath)

\*See Table IV.

**Table IV. DV6 and CCV6 Part numbers**

<b>Assembly P/N</b>	<b>Eccentric weights P/N</b>	<b>Total weight* lb (kg)</b>
XXXXX-01	18013	12.0 (5.4)
XXXXX-02	17046	25.0 (11.3)
XXXXX-03	16275	35.0 (15.9)
XXXXX-04	21689	50.0 (22.7)

\*Weights only. See Tables I and II for total weight of unit.



**Figure 19. Air Motor Caution Label**

## Notes

# Appendix

## BRUTE® Vibrator technical data

Table A-I. BRUTE® Hydraulic Vibrator specifications (CV2.0-2HB model)†

Model	Eccentric setting	Unbalance in-lb (cm-kg)	rpm	gpm L/s‡	Force lb (kg)	rpm	gpm L/s‡	Force lb (kg)	rpm	gpm L/s‡	Force lb (kg)	Max. lb (kg) material in slope portion*
CV2.0-2HB	1**	1.0 (1.15)	2400	2.0 (0.1)	164 (74)	4000	3.0 (0.2)	455 (206)	4650	3.5 (0.2)	614 (279)	6100 (2767)
	2	0.75 (0.86)	2400	2.0 (0.1)	123 (56)	4000	3.0 (0.2)	341 (155)	4650	3.5 (0.2)	461 (209)	4600 (2087)
	3	0.50 (0.58)	2400	2.0 (0.1)	82 (37)	4000	3.0 (0.2)	228 (103)	4650	3.5 (0.2)	307 (139)	3000 (1361)
	4	0.25 (0.28)	2400	2.0 (0.1)	41 (19)	4000	3.0 (0.2)	114 (52)	4650	3.5 (0.2)	154 (70)	1500 (680)

†Data from vibrator mounted to 10,000-lb test block. Frequency and force output will decrease on less rigid mount.

‡‡Per single unit measured at the inlet on the motor.

\*Rule of thumb: 1 lb (0.45 kg) vibrator force for each 10 lb (4.5 kg) of bin content. Reinforce mount area to prevent flexing of walls.

\*\*Normal factory settings.

**Table A-II. BRUTE® Hydraulic Vibrator Specifications<sup>a</sup>**

Model	Eccentric Setting	Unbalance in-lb (cm-kg)	Required psi (bar) to start	rpm	gpm (L/s) <sup>b</sup>	Force lb (kg)	rpm	gpm (L/s) <sup>b</sup>	Force lb (kg)	rpm	gpm (L/s) <sup>b</sup>	Force lb (kg)	rpm	gpm (L/s) <sup>b</sup>	Force lb (kg)	Max. lb (kg) Material in Slope Portion <sup>c</sup>
CC2.8-5HB CV2.8-5HB	1	8.0 (9.2)	180 (12)	2700	4.1 (0.3)	1700 (771)	3200	5.0 (0.3)	2385 (1082)	3700	5.8 (0.4)	3190 (1447)	4400	7.0 (0.4)	4715 (2139)	50,000 (22,680)
	2	7.0 (8.1)	160 (11)	2800	4.2 (0.3)	1605 (728)	3200	5.0 (0.3)	2095 (950)	3900	6.0 (0.4)	3110 (1411)	4500	6.8 (0.4)	3960 (1796)	
	3	6.0 (6.9)	140 (10)	2800	4.5 (0.3)	1335 (606)	3500	5.4 (0.3)	2090 (948)	4100	6.2 (0.4)	2865 (1300)	4600	7.1 (0.4)	3610 (1637)	
	4 <sup>d</sup>	4.5 (5.2)	125 (9)	3300	5.0 (0.3)	1425 (646)	3700	5.5 (0.3)	1790 (812)	4300	6.5 (0.4)	2415 (1095)	4800	7.2 (0.5)	3010 (1365)	
	5	3.0 (3.5)	125 (9)	3800	5.7 (0.4)	1315 (596)	4000	6.0 (0.4)	1455 (660)	4500	6.8 (0.4)	1840 (835)	5000	7.6 (0.5)	2275 (1032)	
	6	2.0 (2.3)	100 (7)	4400	6.0 (0.4)	910 (413)	4400	6.5 (0.4)	1100 (499)	4800	7.2 (0.5)	1310 (594)	5400	8.0 (0.5)	1660 (753)	
CCV4-5HB DV4-5HB	1	8.0 (9.2)	180 (12)	2700	4.1 (0.3)	1680 (762)	3200	5.0 (0.3)	2360 (1070)	3700	5.8 (0.4)	3150 (1429)	4400	7.0 (0.4)	4660 (2114)	95,000 (43,092)
	2 <sup>d</sup>	7.0 (8.1)	160 (11)	2800	4.2 (0.3)	1580 (717)	3200	5.0 (0.3)	2065 (937)	3900	6.0 (0.4)	3070 (1393)	4500	6.8 (0.4)	3905 (1771)	
	3	6.0 (6.9)	140 (10)	2800	4.5 (0.3)	1335 (606)	3500	5.4 (0.3)	2090 (948)	4100	6.2 (0.4)	2865 (1300)	4600	7.1 (0.4)	3610 (1637)	
	4	5.0 (5.8)	125 (9)	3300	5.0 (0.3)	1455 (660)	3700	5.5 (0.3)	1830 (830)	4300	6.5 (0.4)	2470 (1120)	4800	7.2 (0.4)	3075 (1395)	
	5	3.5 (4.0)	125 (9)	3800	5.7 (0.4)	1435 (651)	4000	6.0 (0.4)	1590 (721)	4500	6.8 (0.4)	2015 (914)	5000	7.6 (0.5)	2485 (1127)	
	6	2.5 (2.9)	100 (7)	4000	6.0 (0.4)	1000 (454)	4400	6.5 (0.4)	1210 (549)	4800	7.2 (0.5)	1440 (653)	5400	8.0 (0.5)	1825 (828)	
CCV6-12-8HA DV6-12-8HA	e	12.0 (13.8)	110 (7)	2750	9.0 (0.6)	2200 (998)	3000	10.0 (0.6)	3100 (1406)	3200	11.3 (0.7)	3300 (1497)	3500	12.1 (0.8)	4200 (2769)	125,000 (56,700)
CCV6-25-8HA DV6-25-8HA	e	25.0 (28.8)	125 (9)	2500	8.1 (0.5)	4400 (1996)	2750	9.0 (0.6)	5500 (2495)	3000	10.0 (0.6)	6500 (2948)	3900	11.5 (0.7)	8500 (3856)	200,000 (90,720)
CCV6-50-8HA DV6-50-8HA	e	50.0 (57.5)	150 (10)	1750	6.2 (0.4)	4500 (2041)	2000	7.3 (0.5)	5700 (2586)	2200	8.5 (0.5)	7000 (3175)	2600	9.0 (0.6)	9500 (4309)	400,000 (181,440)

<sup>a</sup> Data from vibrator mounted to 10,000-lb test block. Frequency and force output will decrease on less rigid mount.

<sup>b</sup> Per single unit measured at the inlet on the motor.

<sup>c</sup> Rule of thumb: 1 lb (0.45 kg) vibrator force for each 10 lb (4.5 kg) of bin content. Reinforce mount area to prevent flexing of walls.

<sup>d</sup> Normal factory setting.

<sup>e</sup> Stationary weight.

**Table A-III. BRUTE™ Pneumatic Vibrator Specifications<sup>a</sup>**

Model	Eccentric Setting	Unbalance in-lb (cm-kg)	40 psi (2.8 bar, 0.28 MPa)		60 psi (4.1 bar, 0.41 MPa)		80 psi (5.5 bar, 0.55 MPa)		Max. lb (kg) Material in Slope Portion <sup>c</sup>			
			rpm	cfm L/s <sup>b</sup>	Force lb (kg)	rpm	cfm L/s <sup>b</sup>	Force lb (kg)		rpm	cfm L/s <sup>b</sup>	Force lb (kg)
CC2.8-2A CV2.8-2A	1	8.0 (9.2)	3600	39 (18)	3020 (1370)	4300	52 (25)	4320 (1960)	4700	59 (28)	5145 (2334)	50,000 (22,680)
	2	7.0 (8.1)	3600	48 (23)	2650 (1202)	4300	50 (24)	3780 (1715)	4700	58 (27)	4520 (2050)	
	3	6.0 (6.9)	3700	40 (19)	2335 (1059)	4400	51 (24)	3300 (1497)	4800	60 (28)	3930 (1783)	
	4 <sup>d</sup>	4.5 (5.2)	3800	38 (18)	1890 (857)	4600	51 (24)	2765 (1254)	5000	63 (30)	3270 (1483)	
	5	3.0 (3.5)	3900	37 (17)	1385 (628)	4600	49 (23)	1925 (873)	5100	64 (30)	2365 (1073)	
	6	2.0 (2.3)	4000	37 (17)	910 (413)	4700	53 (25)	1255 (569)	5300	66 (31)	1600 (726)	
CCV4-2A DV4-2A	1	8.0 (9.2)	3300	38 (18)	2500 (1134)	4200	51 (24)	4000 (1814)	4700	58 (27)	5100 (2313)	80,000 (36,288)
	2 <sup>d</sup>	7.0 (8.1)	3400	37 (17)	2400 (1089)	4200	50 (24)	2500 (1134)	4700	56 (26)	4400 (1996)	
	3	6.0 (6.9)	3600	38 (18)	2300 (1043)	4400	49 (23)	3300 (1497)	4900	59 (28)	4100 (1860)	
	4	5.0 (5.8)	3700	37 (17)	2100 (953)	4600	50 (24)	2800 (1270)	5000	62 (29)	3300 (1497)	
	5	3.5 (4.0)	4000	36 (17)	1900 (862)	4730	48 (23)	2200 (998)	5200	63 (30)	2700 (1225)	
	6	2.5 (2.9)	4100	37 (17)	1500 (680)	4840	52 (25)	1700 (771)	5500	65 (31)	1900 (862)	
CCV6-12-6A DV6-12-6A	e	12.0 (13.8)	3000	51 (24)	3069 (1392)	3200	58 (27)	3492 (1584)	3500	65 (31)	4177 (1895)	125,000 (56,700)
CCV6-25-6A DV6-25-6A	e	25.0 (28.8)	2750	53 (25)	5374 (2438)	3000	56 (26)	6393 (2900)	3400	86 (41)	8212 (3725)	250,000 (113,400)
CCV6-50-6A DV6-50-6A	e	50.0 (57.5)	2000	39 (18)	5683 (2578)	2200	44 (21)	6877 (3119)	2600	84 (40)	9605 (4357)	500,000 (226,800)

<sup>a</sup> Data from vibrator mounted to 10,000-lb test block. Frequency and force output will decrease on less rigid mount.

<sup>b</sup> Per single unit measured at the inlet on the motor.

<sup>c</sup> Rule of thumb: 1 lb (0.45 kg) vibrator force for each 10 lb (4.5 kg) of bin content. Reinforce mount area to prevent flexing of walls.

<sup>d</sup> Normal factory setting.

<sup>e</sup> Stationary weight.

## Notes

*Any product, process, or technology described here may be the subject of intellectual property rights reserved by Martin Engineering Company. Trademarks or service marks designated with the ® symbol are registered with the U.S. Patent and Trademark Office and may be proprietary in one or more countries or regions. Other trademarks and service marks belonging to Martin Engineering Company in the United States and/or other countries or regions may be designated with the “TM” and “SM” symbols. Brands, trademarks, and names of other parties, who may or may not be affiliated with, connected to, or endorsed by Martin Engineering Company, are identified wherever possible. Additional information regarding Martin Engineering Company’s intellectual property can be obtained at [www.martin-eng.com/trademarks](http://www.martin-eng.com/trademarks).*

# ***Problem Solved™***



**Martin Engineering USA**  
One Martin Place  
Neponset, IL 61345-9766 USA  
800 544 2947 or 309 852 2384  
Fax 800 814 1553  
[www.martin-eng.com](http://www.martin-eng.com)

Subject to change without prior notice.  
Quality Management System Certified by DNV - ISO 9001

**QUALITY MANAGEMENT SYSTEM  
CERTIFIED BY DNV  
=== ISO 9001:2008 ===**